

When tipping over is not an option ...



05/2020

**Fastening for  
push-pull props MoFi**

**PFEIFER  
ROPE AND LIFTING  
GMBH**

DR.-KARL-LENZ-STRASSE 66  
D-87700 MEMMINGEN

PHONE Technical  
Support +49 83 31-937-345  
Sales +49 83 31-937-231

FAX +49 83 31-937-342

E-MAIL [export-bt@pfeifer.de](mailto:export-bt@pfeifer.de)

INTERNET [www.pfeifer.info](http://www.pfeifer.info)

# Simple and safe installation of concrete walls – no tipping over ...

## The anchor to fasten a push-pull prop ... MoFi



### Maximum process benefits

- Formwork positioning is also possible on automated production lines using electromagnetic pickup on the formwork robot (MoFi 12)
- The push-pull props are fastened using conventional metric thread screws
- Innovative accessories provide considerable time saving at each point of a MoFi's usage cycle



### Maximum safety

- Approved in the whole European Economic Area by European Technical Assessment (ETA)
- Complementary installation and assembly instructions



### Wide range of applications

- Very low minimum shell thicknesses / wall thicknesses  $\geq 50$  mm
- Two practical anchor sizes for absorbing all usual load capacities from wind and slight impact
- Approved for use in waterproof components

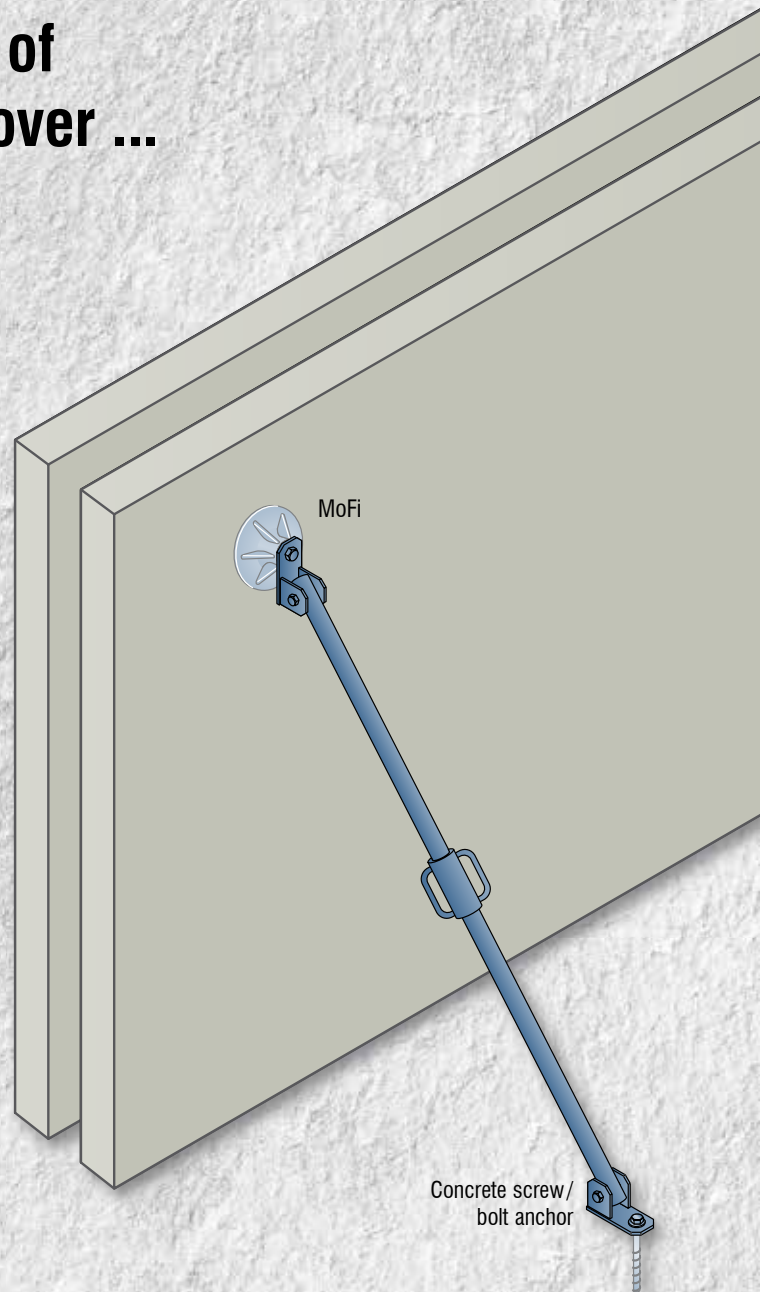

# Fastener for push-pull props



**PFEIFER**

Fixing Systems

Fastener for push-pull props

The Fastener for push-pull props MoFi is fitted in the surface of concrete walls or double wall shells and acts as a secure and technically qualified attachment point for push-pull props during installation. The anchor absorbs loads from wind or slight impact.

**Advantages:**

- **Robotic\*<sup>1</sup>** – can be positioned using formwork robot (MoFi 12)

- Calculable resistances governed by approvals
- Standard thread
- Approved for use in waterproof components
- No prescribed minimum tightening torque
- Twist-resistant due to preformed braces
- Low minimum embedding depth  $\geq 50$  mm
- Safe support in the wall panel through counter-plate (MoFi 12)

**Materials:**

**MoFi 12 Robotic:**  
Fibre-reinforced plastic with internal thread made of steel,  
Plastic cap with integrated, magnetisable metal washer

**MoFi 16:**  
Fibre-reinforced plastic with internal thread made of steel

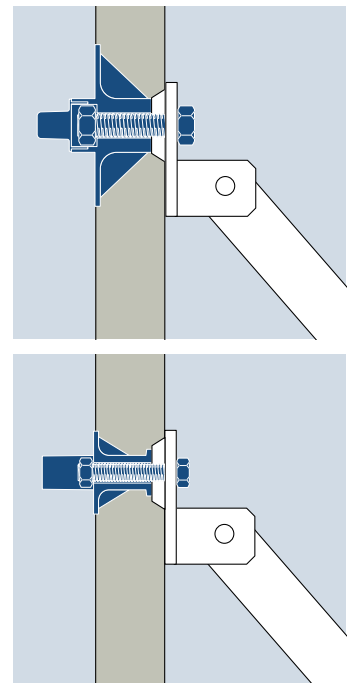
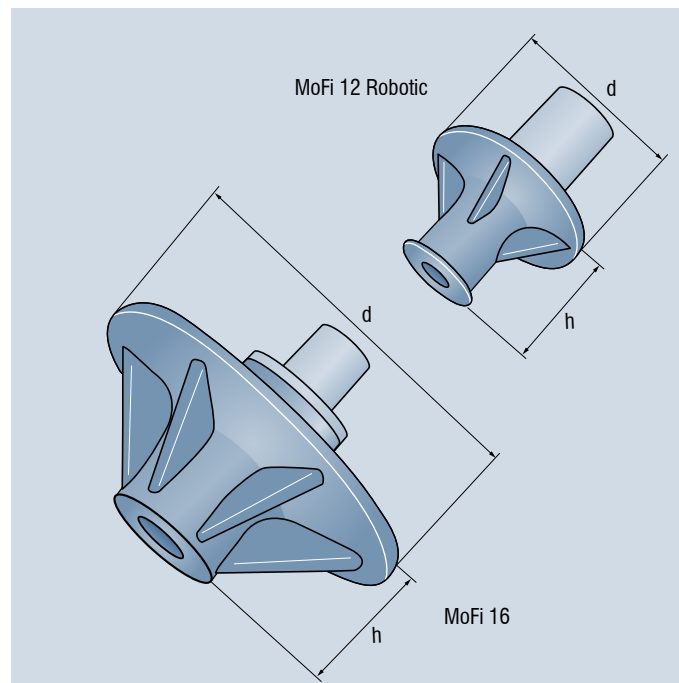

Ref. no.	Type/Size	$F_{Rd}$ [kN]	Thread	h [mm]	d [mm]	Packing unit [pcs.]	Weight/ packing unit [kg]
377027	MoFi-12-Robotic* <sup>1</sup>	see page 11	M12	45	65	50	4,35
268510	MoFi-16	see page 11	M16	45	120	50	11,50



**\*<sup>1</sup> Robotic:**

By means of an integrated metal washer in the yellow plastic cap on the MoFi 12 Robotic, this can be magnetically attracted/held in position. This means – with an electromagnetic pickup on the formwork robot – it can be automatically placed on the formwork. For the highest possible level of automation, the plugged-on magnet fixing (Page 6) suitable for formwork fixing must be pre-assembled on the MoFi. The installation using robot technology is described in more detail on Page 13. Prior suitability tests in the process are recommended.

**! Notice:**

The Fastener for push-pull props MoFi product approval forms an integral part of these instructions for use. In case of discrepancies, the European Technical Assessment **ETA-18/0975** is binding.

the evolution of the MoFi  
through to the current MoFi 12 Robotic

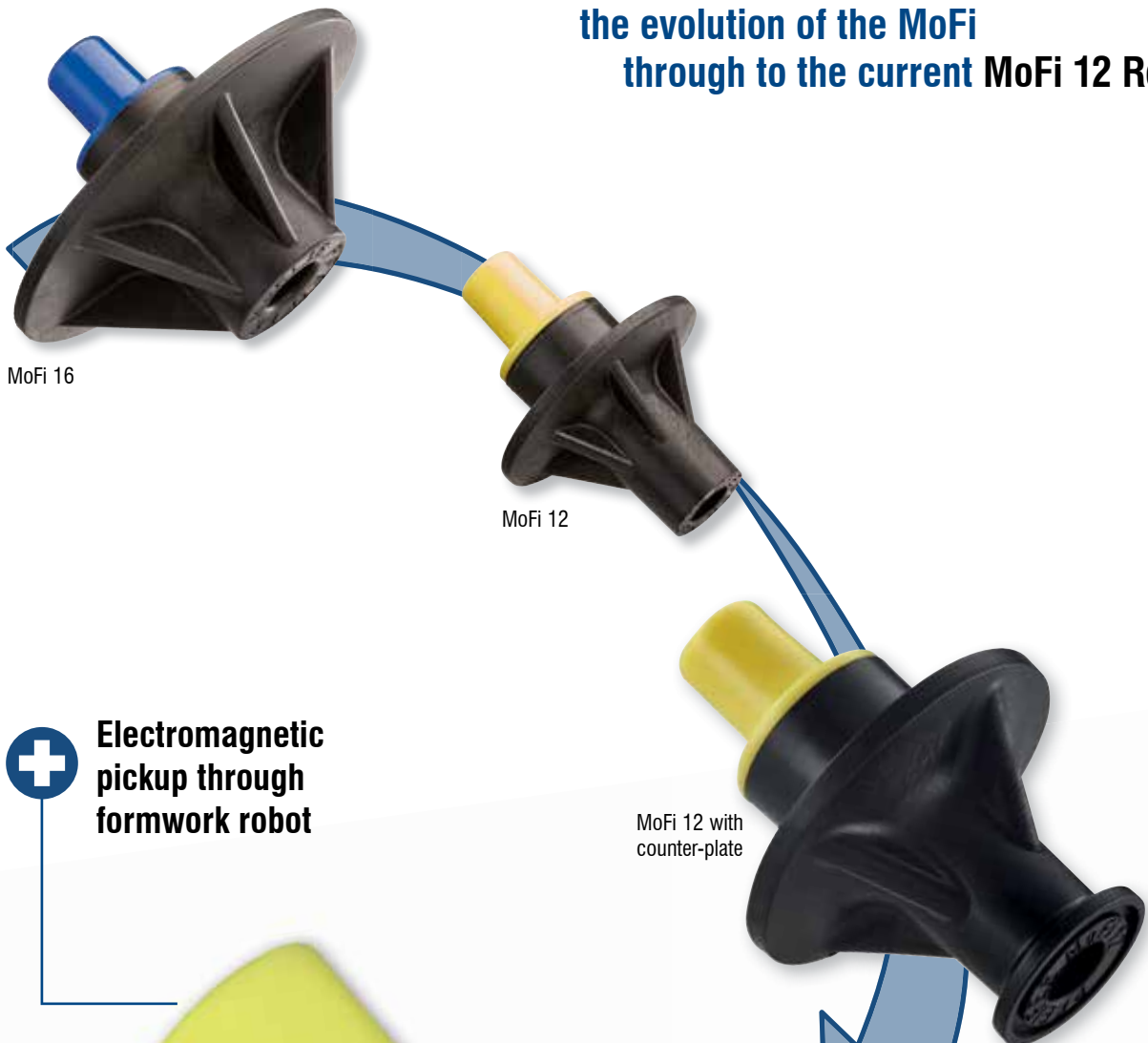

MoFi 16

MoFi 12

MoFi 12 with counter-plate

**+** Electromagnetic pickup through formwork robot

MoFi 12 Robotic

**+** Counter-plate for safe support in the wall panel

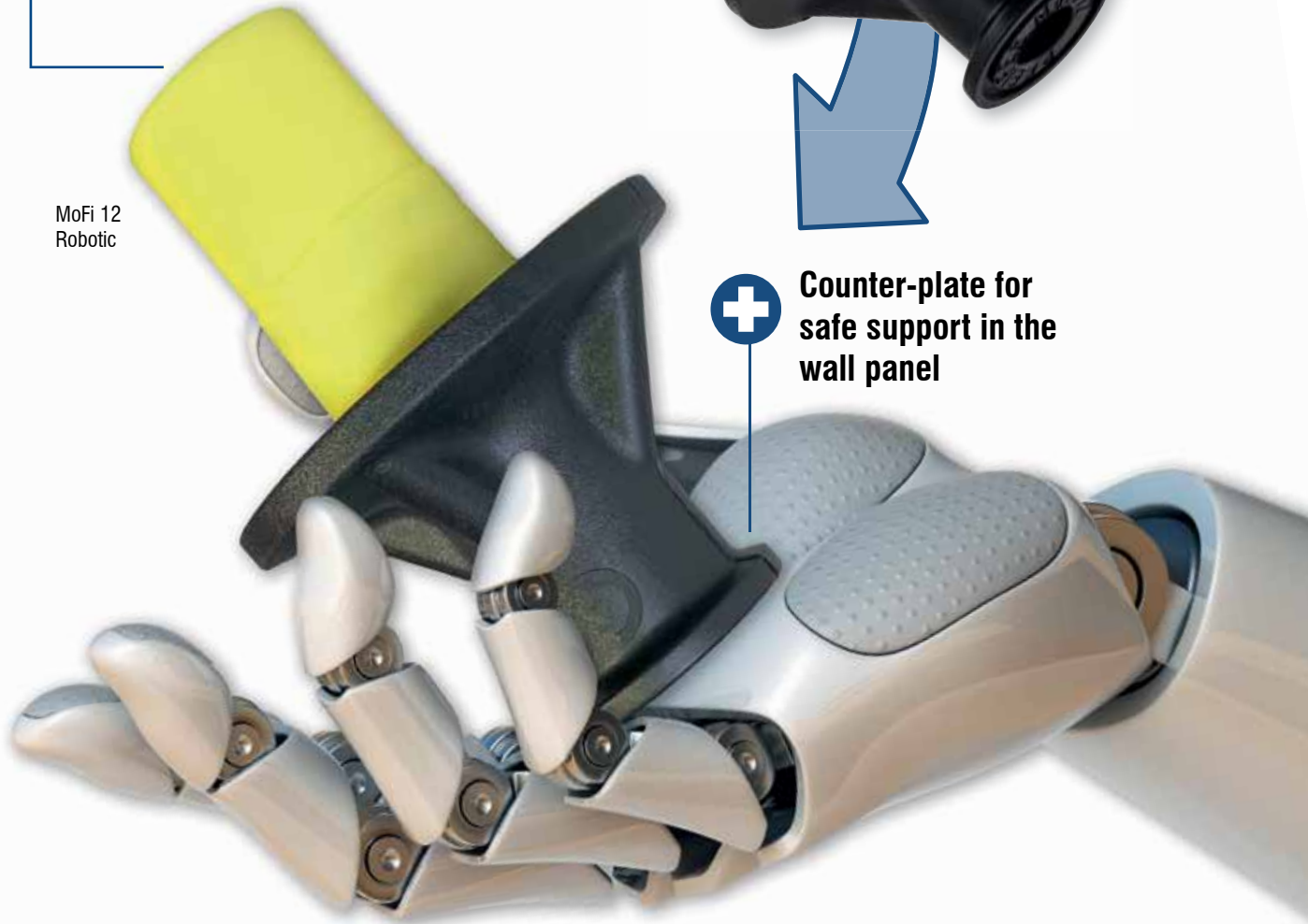

# Ground anchorage



**PFEIFER**

Fixing Systems  
Concrete Screw/Bolt Anchor

To properly fasten the base of a push-pull prop on foundations or slabs during installation, concrete screws and bolt anchors approved throughout Europe can be used. The screws or bolts are for temporarily absorbing wind or similar loads.

- High resistances according to European approval
- Approved for cracked and non-cracked concrete
- Approval-compliant loosening/re-adjusting possible twice (concrete screw)
- Minimum edge/axis distances, as expansion-free anchoring (concrete screw)

### Advantages:

- Time-saving through-hole fitting
- No dowels required

### Materials:

Concrete Screw UCS:  
Steel, galvanized (gvz)

Bolt Anchor MAX:  
Steel, galvanized (gvz)  
available on request in  
stainless steel (A4)

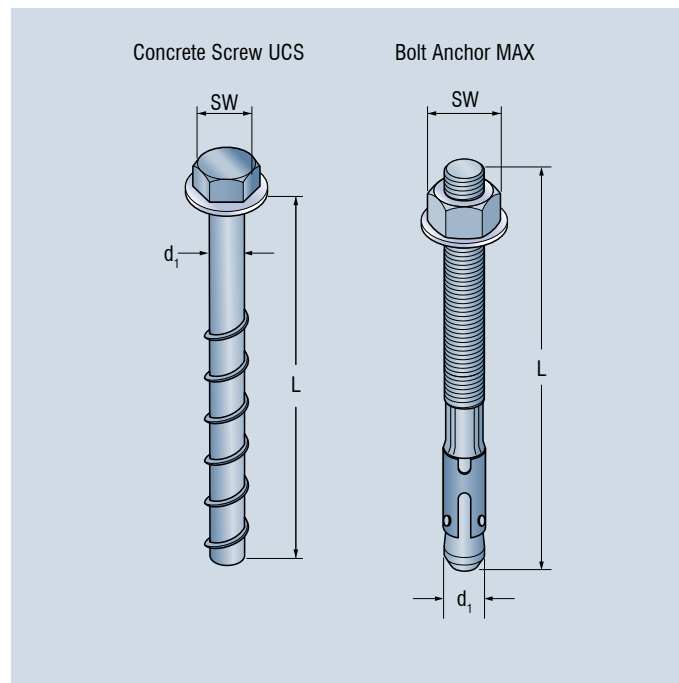

Ref. no.	Type/Size	Drill hole		L [mm]	SW [mm]	Packing unit [pcs.]	Weight/ packing unit [kg]
		Ø d <sub>1</sub> [mm]	depth* <sup>2</sup> [mm]				
396797	UCS-10x100-45/35/15-US	10	110	100	15	50	3,88
396802	UCS-14x125-60/40/10-US	14	140	125	21	10	1,84
396813	MAX-12/10/110-gvz	12	100	110	19	20	2,06
396815	MAX-16/25/148-gvz	16	135	148	24	20	4,74

\*<sup>2</sup> min. drill hole depth in case of through-hole fitting



### ! Notice:

For detailed technical information on dimensioning and usage please refer to the currently valid European Technical Assessments **ETA-18/0762** (Concrete Screw UCS) and **ETA-10/0170** (Bolt Anchor MAX).

# Original accessories for installation and formwork fixing



**PFEIFER**

Fixing Systems  
Accessories

The PFEIFER original accessories include a wide range of solutions for fixing the Fastener of the push-pull prop to the formwork (magnet and plastic recess) and the secure fastening of the push-pull props themselves to the fastener (fixing bolt).

### Advantages:

- Simple formwork fixing/installation
- Easy removal of the magnet fixings using the thread/hex socket of the magnetic disk
- No piercing of or welding to steel formwork necessary (magnet fixing)
- Reusable (magnet fixing and fixing bolt)

### Materials:

Plastic fixing:  
Plastic

Magnet fixing  
plugged-on/screwed:  
Steel high-strength, galvanized

Fixing bolt:  
Steel high-strength, galvanized

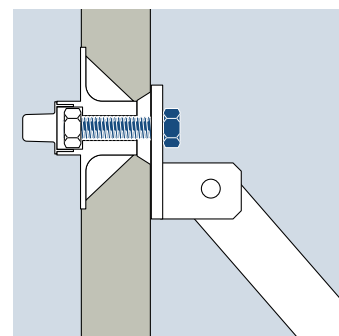
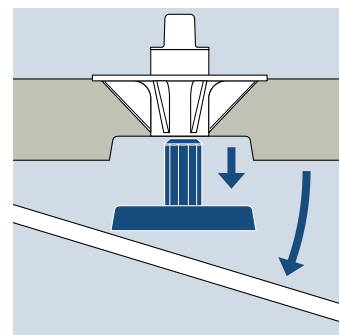
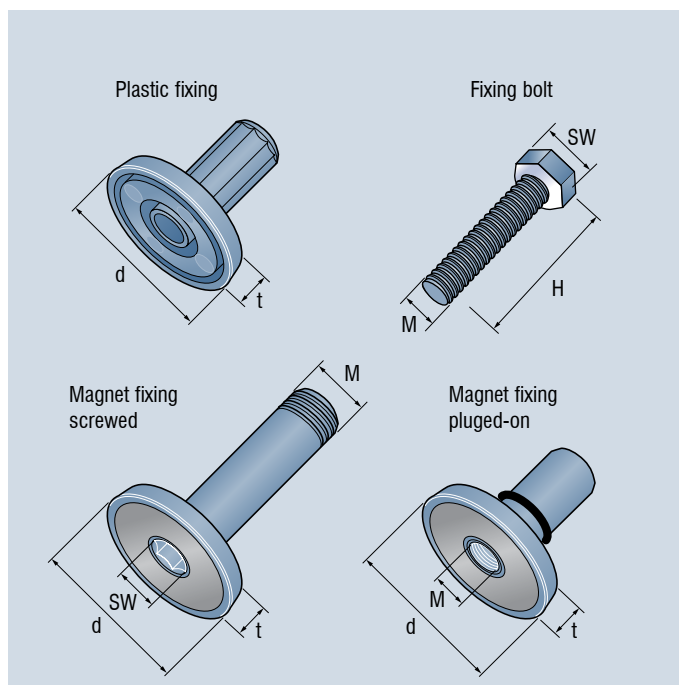

Ref. no.	Product	Type	Assignment	Thread	H	d	t	SW	Packing unit [pcs.]	Weight/packing unit [kg]
					[mm]	[mm]	[mm]	[mm]		
289061	Fixing bolt	BSC-12	MoFi 12	M12	95	-	-	18	25	2,00
275209	Fixing bolt	BSC-16	MoFi 16	M16	95	-	-	21	25	4,75
330520	Magnet fixing plugged-on	MAM-12-GT	MoFi 12	M6	-	44	8	-	2	0,18
375160	Magnet fixing plugged-on	MAM-16-GT	MoFi 16	M8	-	52	8	-	2	0,32
300043	Magnet fixing screwed	MAM-12-GS	MoFi 12	M12	-	44	8	10	2	0,20
376638	Magnet fixing screwed	MAM-16-GS	MoFi 16	M16	-	52	8	10	2	0,36
287251	Plastic fixing	KAM-12	MoFi 12	-	-	43	8	-	50	0,50
270921	Plastic fixing	KAM-16	MoFi 16	-	-	52	8	-	50	0,60

# Original accessories for closing the recess



**PFEIFER**

Fixing Systems  
Accessories

The PFEIFER original accessories also includes a range of solutions for cost-effectively closing the recess of the push-pull prop left in the concrete.

**Advantages:**

- Appealing, predictable appearance
- Considerable time-saving when closing anchors
- Colours can be individually adapted on request

**Materials:**

Concrete plug:  
Fibre reinforced concrete

Plastic plug:  
Plastic

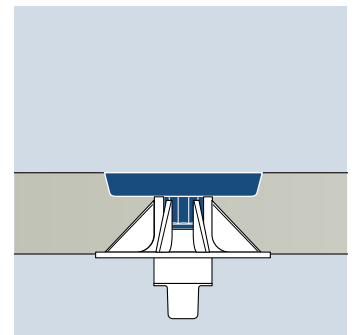
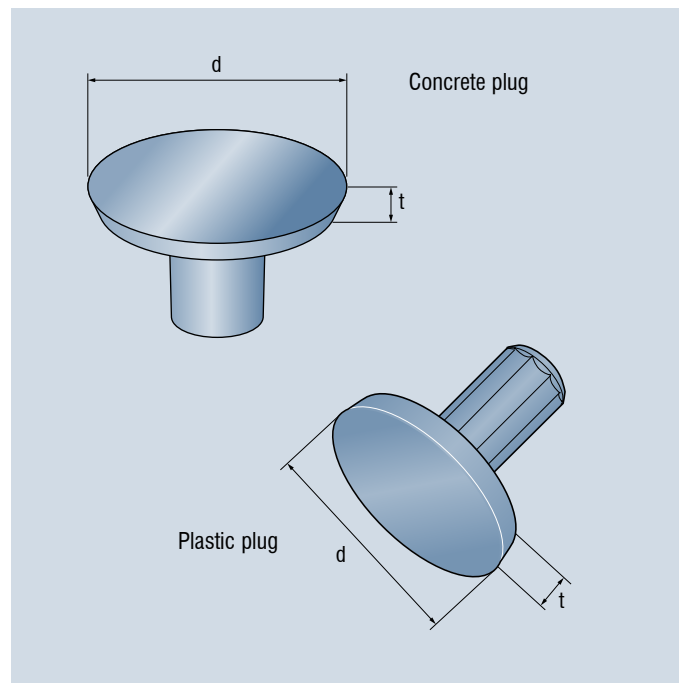

Ref. no.	Product	Type	Assignment	d	t	Packing unit	Weight/ packing unit
				[mm]	[mm]	[pcs.]	[kg]
287287	Plastic plug	VSTM-K-12	MoFi 12	43	8	50	0,30
273624	Plastic plug	VSTM-K-16	MoFi 16	52	8	50	0,35
290593	Concrete plug	VSTM-B-12	MoFi 12	42,7	7	50	1,00
278349	Concrete plug	VSTM-B-16	MoFi 16	51,6	7	50	1,80

## System description

### Push-pull prop head:

Fastener for push-pull props  
MoFi 12 Robotic  
MoFi 16

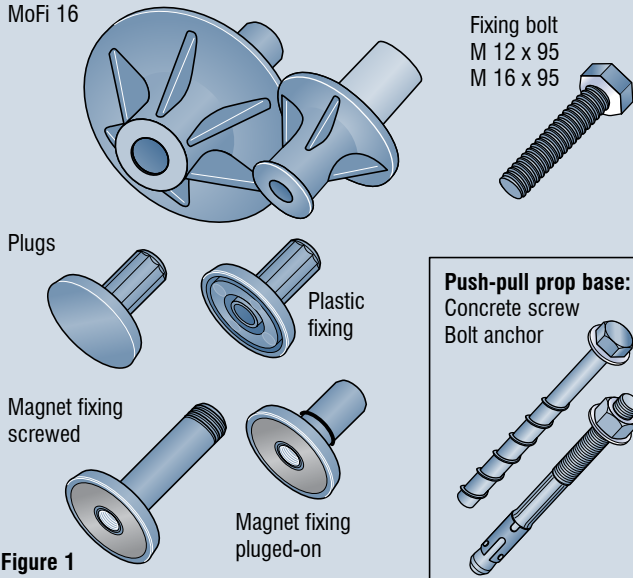

Figure 1



### Notices:

- Fastener for push-pull props MoFi, concrete screw and bolt anchor can be used independently of one another.
- The design/selection of the push-pull prop is not included with the PFEIFER system. This must be done by the responsible planner/fitter himself in accordance with the current state of the art.

The PFEIFER fixing for push-pull props is a complete system and consists of the Fastener for push-pull props MoFi in combination with the formwork fixing in a plastic or magnetic version as well as a concrete screw or alternatively a bolt anchor for fastening to the foundation or to a floor slab.

### System components on the push-pull prop head:

- As a fastening point for the push-pull prop head:  
PFEIFER Fastener for push-pull props MoFi 12 Robotic/MoFi 16
- For fastening the MoFi to the formwork: PFEIFER plastic/magnet fixing
- For fastening the push-pull prop head to the MoFi:  
M12/M16 screw, strength grade 8.8 according to DIN EN ISO 898-1 (provided by customer or from PFEIFER range)
- M12/M16 washer (customer/not supplied by PFEIFER/to suit the fixture) or adapter sleeve (specific to the push-pull prop)
- For closing the remaining recess:  
Optional PFEIFER plug concrete/plastic

### System components on the push-pull prop base:

- For fastening the push-pull prop base to the foundations/slab: Concrete screw or alternatively bolt anchor (suitable size taking into account the resistances)



### Warnings:

- The use of other elements for formwork fixing could lead to reduced depths of embedding and therefore to reduced carrying capacities. Use only original accessories.
- Using bolts and washers of lower quality is not permissible and reduces the intended carrying capacities. Use only suitable bolts as specified.
- The concrete screws must never be screwed into the Fasteners for push-pull props MoFi. There is a risk of incalculable carrying capacities. Danger to life.

## Intended use

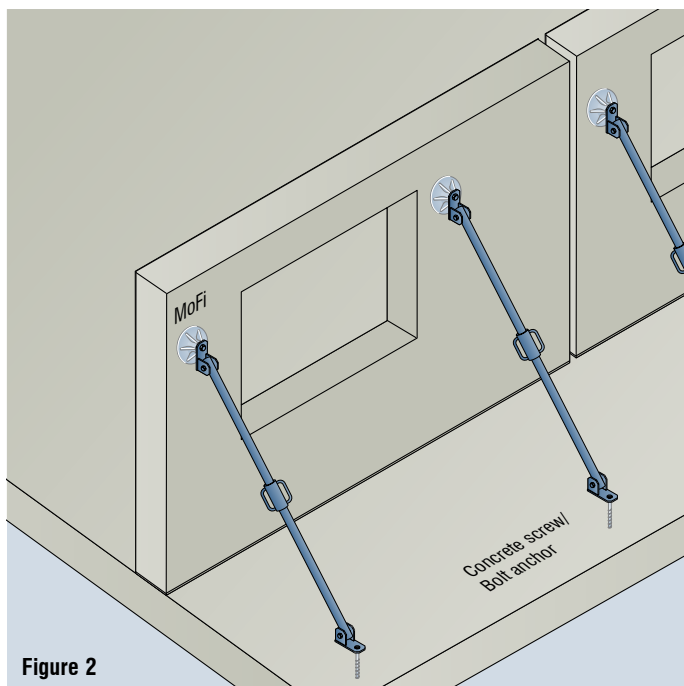

Figure 2

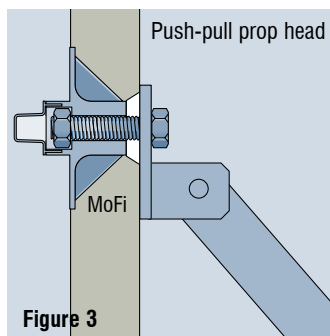

Figure 3

The push-pull props can be temporary fastened using the PFEIFER Fasteners for push-pull props MoFi, the concrete screws and the bolt anchors. In this context, the Fastener for push-pull props MoFi is intended for being installed in the precast element and the concrete screw/bolt anchor in the in-situ concrete floor or in the foundations. They are able to take stresses arising from wind or other temporary loadings. In this context, it is important to pay attention to the correct selection of bolts, washers and braces (stays) that withstand tension and compression forces.

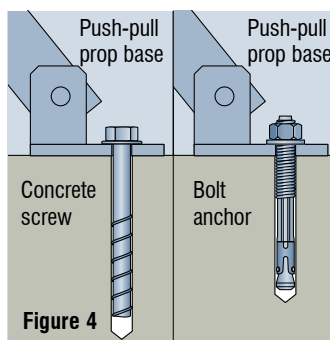

Figure 4



### Notice:

Fixing to solid panels using the fasteners for push-pull props MoFi can similarly be done. In this case pay particular attention to the maximum possible screw-in depth since, owing to the cap, there is only limited freedom for accepting length tolerances of the bolt.



### Notice:

When selecting the positions and number of the anchors, always ensure stable fixing and support. As a rule, at least two push-pull props and two anchors are needed per wall panel.



## Intended use

### Fastener for push-pull props MoFi 12 Robotic/MoFi 16

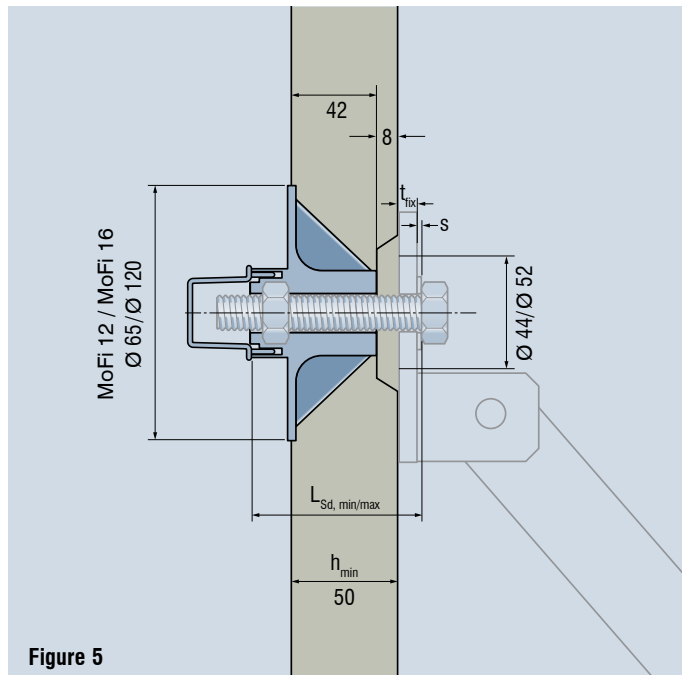

Figure 5



Figure 6

#### Assembly of one push-pull prop with Fastener for push-pull props MoFi 12 Robotic/MoFi 16 at the head

1. Select a suitable fastening bolt M12/M16 – 8.8  
→ When the PFEIFER M12/M16 x 95 fixing bolt is used, the overall dimension “ $t_{fix} + s$ ” can be in the range 5-25 mm.
2. Select a suitable push-pull prop as specified by the planner.
3. Use an M12/M16 fixing bolt to secure the push-pull prop to the MoFi 16 Robotic/MoFi 16  
→ Observe the maximum assembly torque  $T_{inst}$  according to the valid approval! (see also fig. 7)
4. Fasten the push-pull prop according to drawing specification
5. Observe angle of inclination!



#### Notice:

minimum bolt length  $L_{Sd,min}$ :  $t_{fix} + s + 70$  mm  
maximum bolt length  $L_{Sd,max}$ :  $t_{fix} + s + 90$  mm



#### Caution:

- In the assembly process ensure that the actual angle of the brace is as intended in the plan. With less favourable boundary conditions an overloading of the anchors must be assumed and they are likely to fail. Always comply with the permitted angle of inclination.
- The fixing bolt must always be screwed completely into the anchor thread in order to attain the full load capacity. With a smaller screw-in depth the carrying capacity is reduced and there is a threat of failure.
- The bolt must be used only once in the same borehole. Screwing it into the same borehole twice causes reduced resistance values and can cause danger to life and limb.

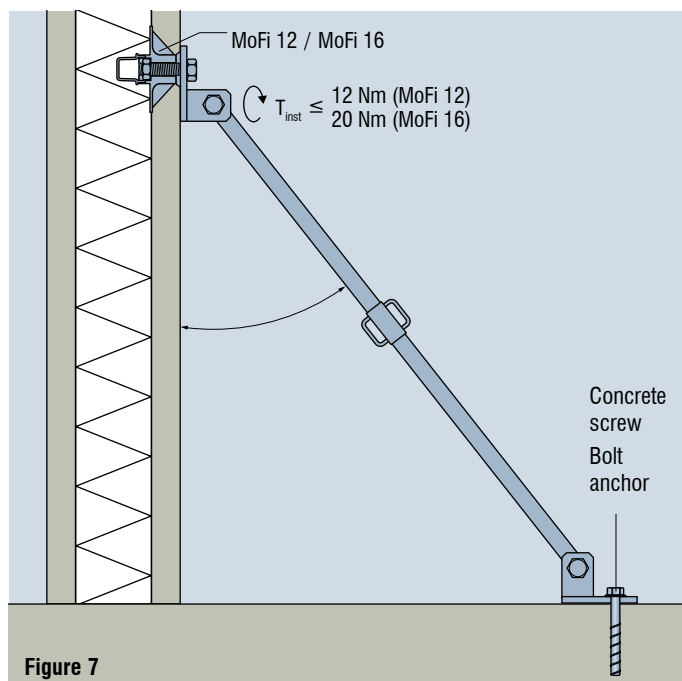

Figure 7



#### Notices:

- To prevent excessive torque to the nut of the MoFi when mounting the push-pull prop using a power screwdriver, the maximum specified torque moment must be ensured with an appropriate cut-off device. The screwdriver must be applied with appropriate care. Alternatively, tools without specified torque moment can be used.
- The push-pull prop is correctly anchored if the whole area of the fixed base plate is bolted to the concrete without an intermediate layer and the screw-in/seating depths, etc. comply with the approvals.

# Instructions for installation and use

## Intended use

### Application in impermeable concrete buildings

As built-in components in impermeable concrete buildings must generally be assessed as critical, they must not be used without further examinations. Tests to establish the water penetration depth under pressure were carried out in accordance with DIN EN 12390-8:2009-07 for the technical assessment of the usability of MoFi 12 and 16 PFEIFER Fasteners for push-pull props.

These standard tests were carried out for an unfavourable case wherein the (external) wall panel opposite the built-in component of a double wall element is exposed to water pressure of 500 kPa (Figure 8). The water pressure applied usually covers the range of common building construction.



#### Notice:

Pursuant to the report **BRE-G326-01** of the Technical University of Kaiserslautern dated 12 December 2017, the use of PFEIFER Fasteners for push-pull props MoFi for professionally manufactured impermeable concrete buildings can be assessed as uncritical when installed in the interior shell of double walls.

#### The following boundary conditions must be adhered to:

General compliance with the recognised rules of technology for waterproof constructions, such as: DAFStb guideline Book 555 "Waterproof concrete structures" (WU guideline)

In particular the following points must be observed here:

- Shell thickness  $\geq 50$  mm
- All connection details are to be designed in particular with attention on the protection against water ingress (e.g. arrangement of metal water stops or joint sealing tapes)
- Minimum thickness of the in-situ concrete addition must meet the WU guideline

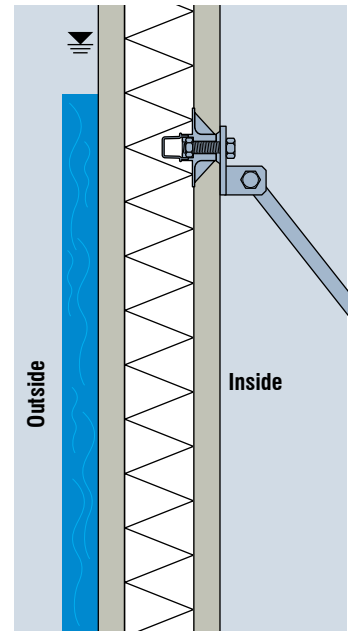

Figure 8

## Dimensioning

The resistances specified in the section "Dimensioning" in table 1 apply in all directions (with the exception of loads in the direction transverse to the longitudinal axis/plane of the push-pull prop, similar to Figure 9). The responsible planner can do the dimensioning with the indicated resistance values, taking account of all possible stresses such as light collisions, wind, tipping, etc. In doing this, the minimum edge and intermediate distances as in Table 2 must be complied with.

#### Providing verification:

$$\frac{F_{Ed}}{F_{Rd}} \leq 1,0$$



#### Warning:

The indicated resistance values always refer to the bolt axis. Load-increasing influences from the push-pull props employed may need to be specially determined.



#### Notice:

Compressive forces that arise are born by the bottom contact area of the push-pull prop. This must be specifically verified by the responsible planner. The circular area of the moulding insert on the MoFi anchor must be taken into account as a missing contact area.

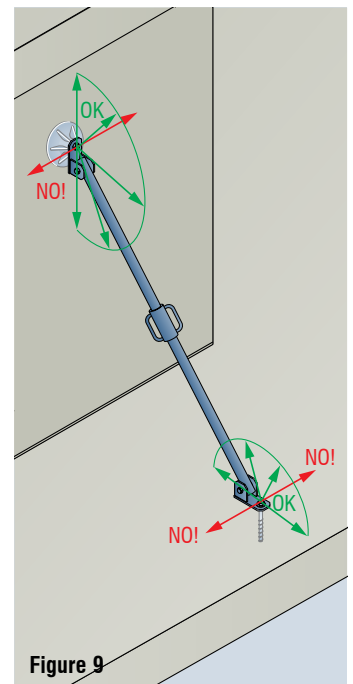

Figure 9

## Dimensioning

**Table 1: PFEIFER Fastener for push-pull prop design resistances**

		MoFi 12 [kN]	MoFi 16 [kN]
<b>Non-cracked</b> concrete concrete strength class C20/25 to C50/60	$F_{Rd,ucr}$	13,0	22,0
<b>Cracked</b> concrete concrete strength class C20/25 to C50/60	$F_{Rd,cr}$	9,3	15,7

**! Notice:**

The given resistance values do not apply in the direction transverse to the longitudinal axis/plane of the push-pull prop. Loading is intended and permissible only in the axis of the push-pull prop! See Figure 9.

**Table 2: Minimum distances from edge**

Typ	Minimum edge distance in load direction c [mm]	Minimum intermediate distance b [mm]	Minimum distance to edge transverse to load direction a [mm]
MoFi 12	300	400	200
MoFi 16	1000	800	400

**! Notice:**

Minimum surface reinforcement Q188 ( $\triangleq 1.88 \text{ cm}^2/\text{m}$ ) in each case at least a full mesh field in each direction.

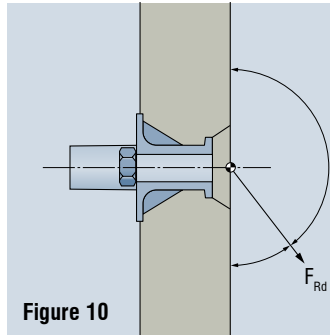

Figure 10

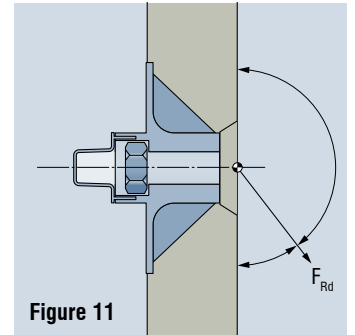

Figure 11

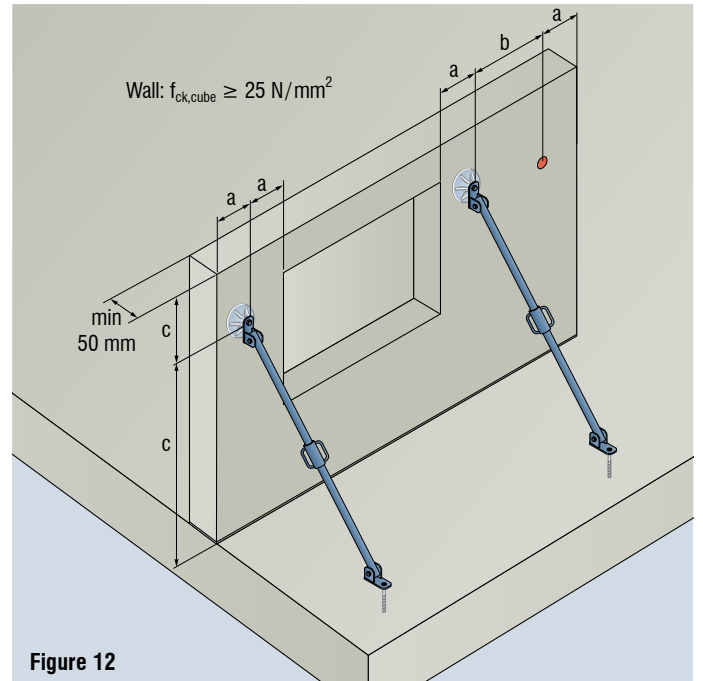
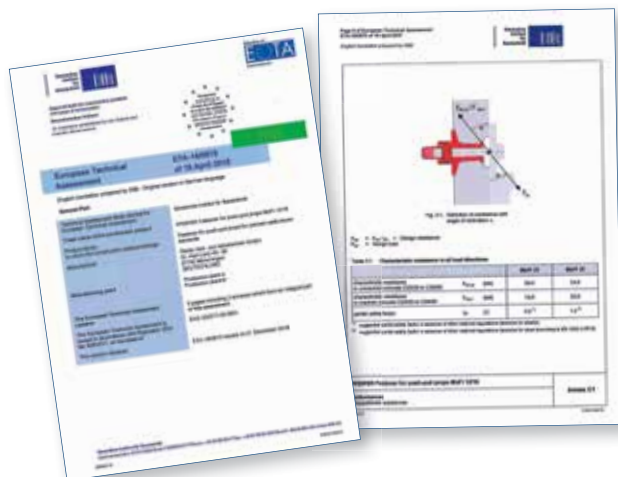

Figure 12



### European Technical Assessment (ETA) of the PFEIFER Fastener for push-pull props MoFi:

Now at [www.pfeifer.info/mofi-fastener](http://www.pfeifer.info/mofi-fastener)



Approval:  
ETA



## Design example

### Assumptions:

- Double wall dimensions: 6,75 m x 3,0 m
- Shell thickness: 50 mm
- Concrete compressive strength wall\*<sup>3</sup>:  $f_{ck,cube} \geq 25 \text{ N/mm}^2$
- Surface reinforcement: Q188
- Wind pressure ( $h \leq 10 \text{ m}$ ; wind zone 2):  $q_p = 0,65 \text{ kN/m}^2$   
(according to DIN 1991-1-4/NA:2010-12, Tab. NA.B.3)
- Push-pull prop inclination:  $\alpha = 50^\circ$
- 2 push-pull props (= 2 x MoFi + 2 x ground anchoring)
- No further relevant stresses during assembly (snow, earthquake, collision)
- Assembly period is between May and August (maximal 3 months) or assembly takes 3 days at the most

### Static model:

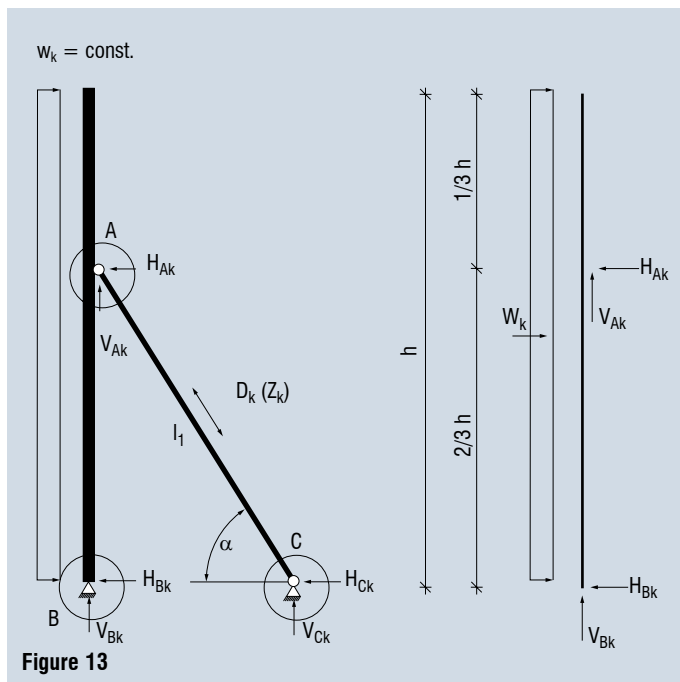

Figure 13

\*<sup>3</sup> strength measured on the construction site

### Proof:

Chosen: **Fastener for push-pull props MoFi 16**

$$F_{Ed} = D_k \cdot \gamma_w \cdot \frac{1}{\text{number of anchors}} = 26,12 \text{ kN} \cdot 1,5 \cdot \frac{1}{2} = 19,59 \text{ kN} \leq F_{Rd,ucr} = 22,00 \text{ kN} \text{ (assumption: non cracked concrete)}$$

Proof met



### Notices:

- This example dimensioning is limited to determining the forces, in relating to the Fastener for push-pull props MoFi 16. A Fastener for push-pull props MoFi 12 Robotic is dimensioned in the same way. The ground anchoring by means of concrete screw or bolt anchor is to be verified separately.
- For complete dimensioning, the proofs for the push-pull prop itself, the load capacity of the attached elements and the securing of the bottom point of the concrete element against shifting (point B Fig. 3) must be prepared too. The dimensioning was done with the assumption that there are no stress-increasing effects from the geometry of the push-pull prop bases.
- As a matter of principle, the smallest design resistance of all components involved is decisive!

### Determination of wind effect:

Velocity pressure:	$q_p = 0,65 \text{ kN/m}^2$
Reduction for state of construction:	$red_{Wind} = 0,5$ (DIN EN 1991-1-4/NA:2010-12, Tab. NA.B.5)
Pressure coefficient:	$c_{p,net} = 3,4$ (Referring to a long wall, area A)

### Characteristic wind load:

$$W_k = w_k \cdot b \cdot h = 1,105 \frac{\text{kN}}{\text{m}^2} \cdot 3,0 \text{ m} \cdot 6,75 \text{ m} = 22,38 \text{ kN}$$

with

$$W_k = q_p \cdot c_{p,net} \cdot red_{Wind} = 0,65 \frac{\text{kN}}{\text{m}^2} \cdot 3,4 \cdot 0,5 = 1,105 \text{ kN/m}^2$$

### Determination of relevant loads:

$$\begin{aligned} \sum M_B = 0: & \quad H_{Ak} = W_k \cdot \frac{3}{4} = H_{Ck} \\ & \quad H_{Ak} = H_{Ck} = 22,38 \text{ kN} \cdot \frac{3}{4} = 16,79 \text{ kN} \\ \sum H = 0: & \quad H_{Bk} = W_k - H_{Ak} \\ & \quad H_{Bk} = 22,38 \text{ kN} - 16,79 \text{ kN} = 5,59 \text{ kN} \\ \sum V = 0: & \quad V_{Bk} = 0,9 \cdot G_k - V_{Ak} \end{aligned}$$

### Determination of stay force:

$$D_k = \frac{H_{Ak}}{\cos(50^\circ)} = \frac{16,79 \text{ kN}}{\cos(50^\circ)} = 26,12 \text{ kN}$$

### Determination of required stay length:

$$l_1 = \frac{\frac{2}{3} \cdot h}{\sin(50^\circ)} = \frac{\frac{2}{3} \cdot 6,75 \text{ m}}{\sin(50^\circ)} = 5,87 \text{ m}$$

## Installation

### Fastener for push-pull props MoFi 12 Robotic / MoFi 16

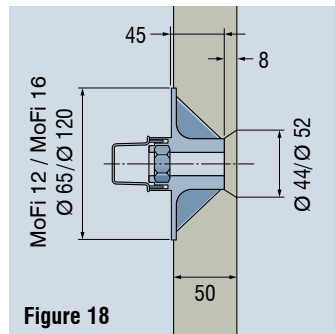
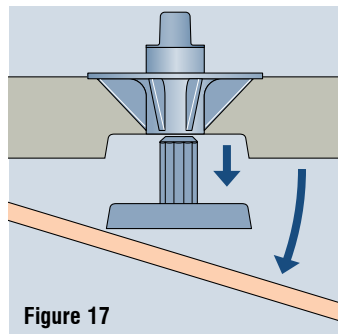
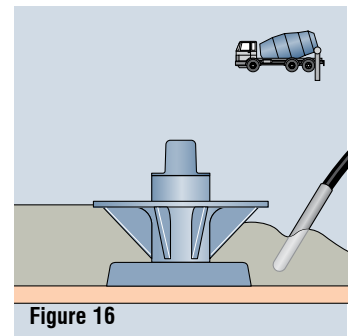
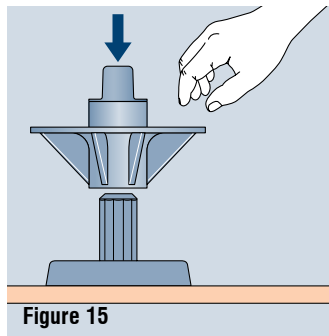
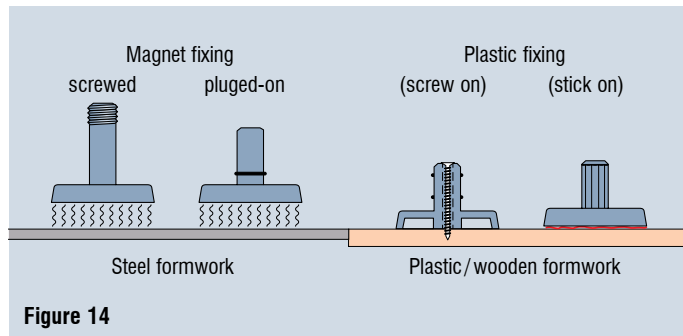

#### Attention:

Plastic or magnetic recesses are always an integral part of the system and must therefore be used. Using other fasteners or omitting them can lead to reduced load-bearing capacities and thus to danger to life and limb.



#### Notes on plastic recesses:

- The plastic recesses must be placed tightly one on top of the other to prevent the MoFi from floating up later during the compaction process.
- In general, the plastic recesses are intended for single use only!
- Multiple plugging on the MoFi leads to wear of the flanks on the shaft and also causes the MoFi to fill with concrete.



#### Note:

- In the illustrations (Figs. 14 to 18), only the attachment using the plastic recess was shown. The variant with magnetic recess should be used accordingly.
- When compacting the concrete, care must be taken to ensure that built-in parts are not displaced and that the anchoring area does not show any defects.
- Surrounding reinforcement must not touch the MoFi directly and should be at a sufficient distance from the MoFi! Any existing or touching reinforcement can cause the MoFi to loosen/detach from the formwork fastening and fill with concrete.



#### Note on magnetic recesses:

In case a magnetic recess remains in the wall panel after removing the formwork, it can be easily removed from the component using an Allen key (screwed version) or a suitable screw (plugged version).

## Installation using robot technology

### Fastener for push-pull props MoFi 12 Robotic

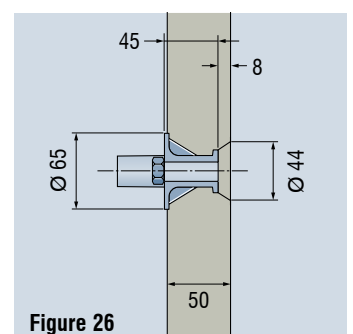
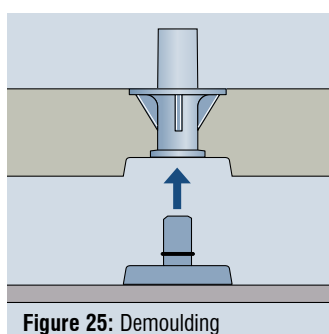
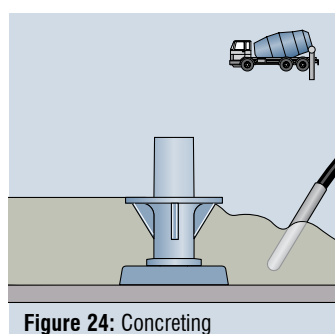
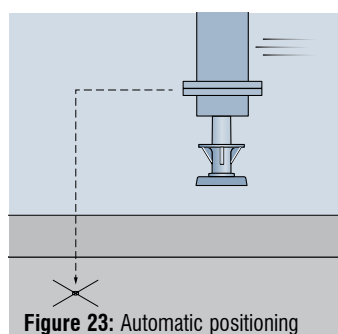
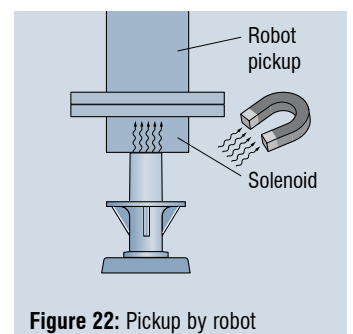
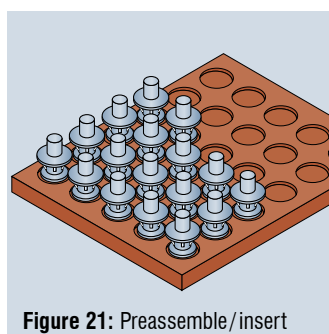
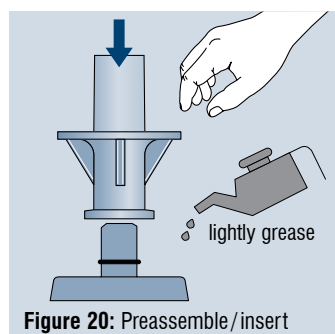
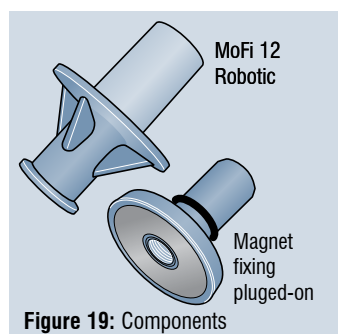

## Installation

### Concrete plug

1. Cleaning the surfaces

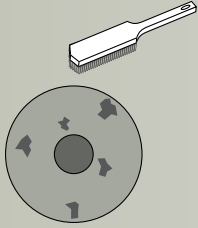

Figure 27

2. Checking the type and size

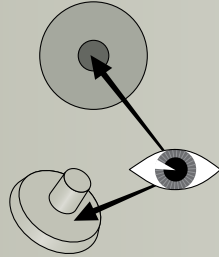

Figure 28

3. Applying the adhesive

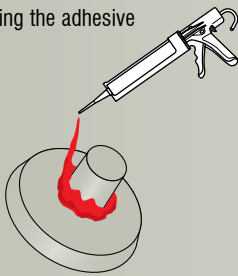

Figure 29

4. Press in carefully

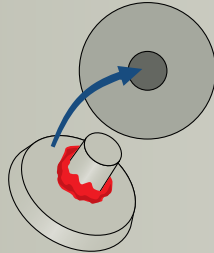

Figure 30

5. Positioning centrally

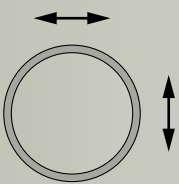

Figure 31



#### Caution:

Too large a quantity of adhesive can lead to the excess being squeezed out and impair the appearance. It is important to ensure the amount is suitable and uniformly applied. If there is doubt, do a preliminary trial application.



#### Notice:

- Figures 27 to 31 show the general installation of the PFEIFER concrete plugs. To achieve an ideal appearance, it is generally necessary to ensure careful execution.
- The more carefully the concrete cover cap is aligned to the longitudinal and transverse axes, the more inconspicuous the items will be in the overall appearance (Fig. 31).

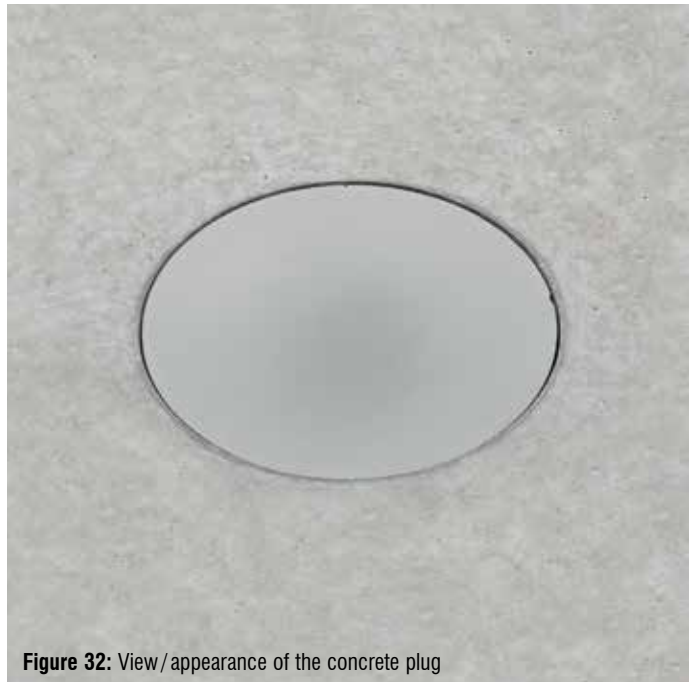

Figure 32: View/appearance of the concrete plug

### Plastic plug

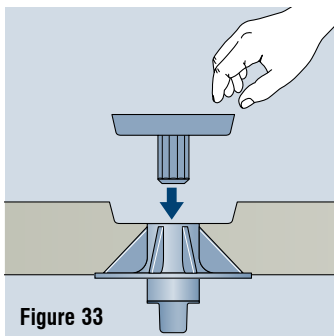

Figure 33



#### Notice:

The PFEIFER plastic plug guarantees a sufficient connection of the two products by simply pushing it into a Fastener for push-pull props MoFi. The recess closure fits exactly into the system recess remaining in the concrete.

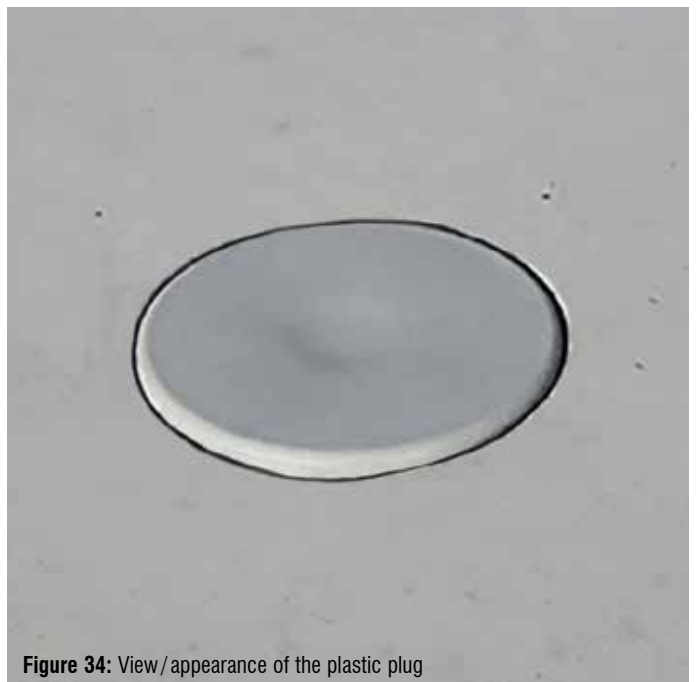
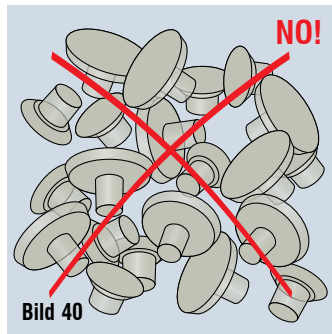
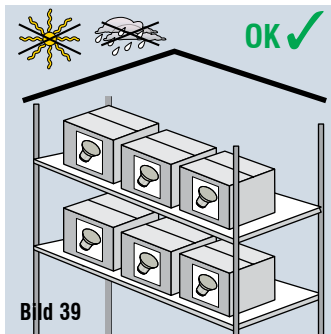
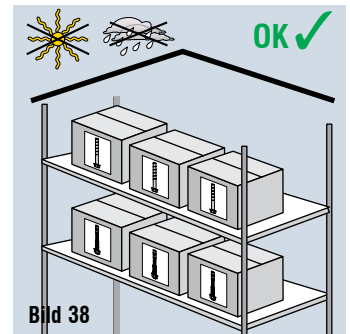
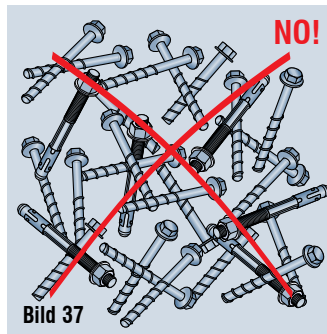
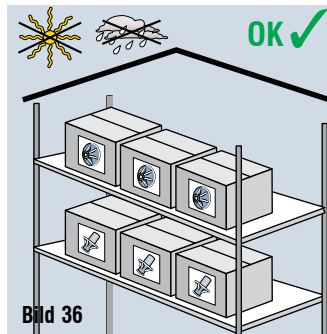
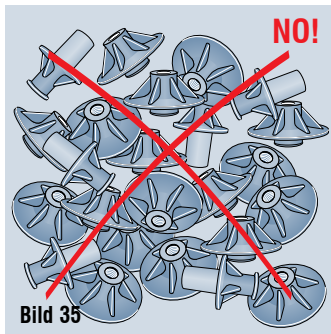

Figure 34: View/appearance of the plastic plug

## Storage



## Notes about weathering

### Fastener for push-pull props MoFi 12 Robotic / MoFi 16

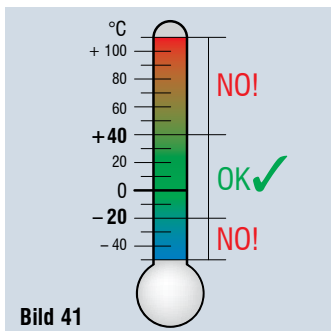

#### ! Notices:

- Tests showed that a MoFi not embedded in concrete retains its load bearing capacity even after a weathering period of 12 months.
- The PFEIFER Fasteners for push-pull props MoFi are designed to be exposed to direct UV radiation for not longer than 12 months before use.
- Figure 41 shows the temperature limits for using the MoFi.

## Checklist

- Were all stresses during assembly taken into account for the dimensioning?
- Was the push-pull prop verified for all stresses and were the manufacturer's specifications taken into account?
- Were all proofs met for the anchoring of the push-pull prop head and base?
- Were the slab thickness of the brace head and base taken into account when determining the bolt length?
- Do the screw-in depths comply with the approval?

# PFEIFER



The contact details of our locations and sales partners can be found at



[www.pfeifer.info/contacts-cls](http://www.pfeifer.info/contacts-cls)

We look forward to hearing from you!

This document is superseded when a new edition appears at [www.pfeifer.info](http://www.pfeifer.info).

**PFEIFER  
ROPE AND LIFTING  
GMBH**

DR.-KARL-LENZ-STRASSE 66  
D-87700 MEMMINGEN

PHONE Technical  
Support +49 83 31-937-345  
Sales +49 83 31-937-231

FAX +49 83 31-937-342

E-MAIL [export-bt@pfeifer.de](mailto:export-bt@pfeifer.de)

INTERNET [www.pfeifer.info](http://www.pfeifer.info)