

Instructions for installation and use

PFEIFER Load eye

Attachment point for load attachment devices, satisfying EC machinery directive 2006/42/EC



Attachment point for personal safety equipment Z-14.9-778



PFEIFER

Fixing Systems
Lift Installation

Attachment point for personal safety equipment
PFEIFER load eyes are attachment points for the temporary attachment of material loads or personal safety equipment during assembly or maintenance work. They are intended for top-sided installation in steel reinforced concrete ceilings.

Material:

Special-quality steel
Retaining box - plastic

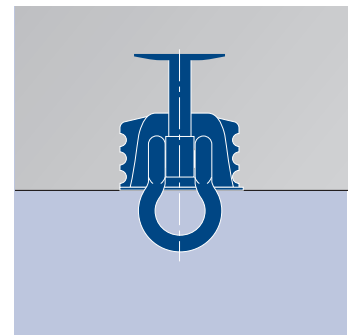
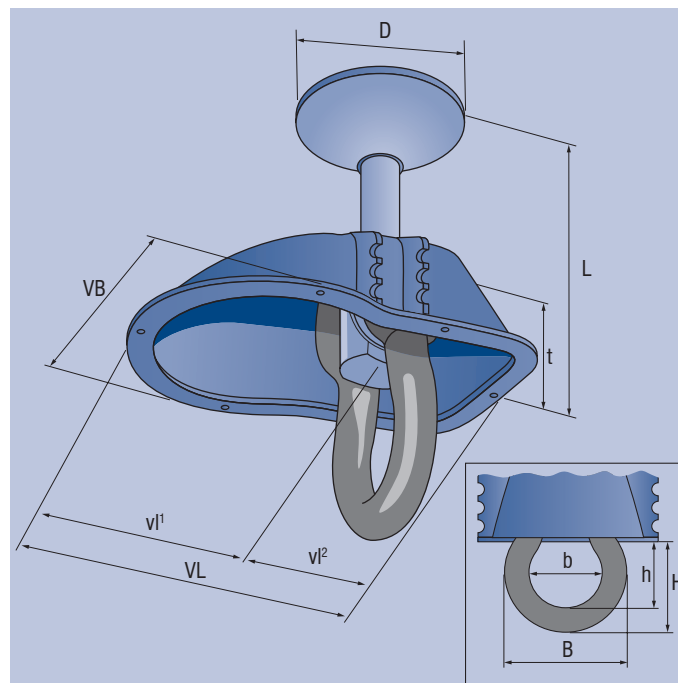

Ref. no.	Carrying capacity kg	WLL kN	Colour Retaining box	Dimensions mm												Weight kg/piece
				D	L	VL	v1'	v1''	VB	t	h	H	B	b		
265242	2000	20	blue	90	130	195	125	70	132	60	55	75	90	50	2,1	
265241	4000	40	red	90	200	195	125	70	132	60	55	75	90	50	2,3	

Example order for 10 PFEIFER load eyes with a load capacity of 2000 kg / WLL 20 kN:
10 PFEIFER load eyes 20; WLL 20 kN; order number 265242

Instructions for installation and use of PFEIFER load eyes

Attachment point for load attachment devices, satisfying EC machinery directive 2006/42/EC
Attachment point for personal safety equipment Z-14.9-778

System

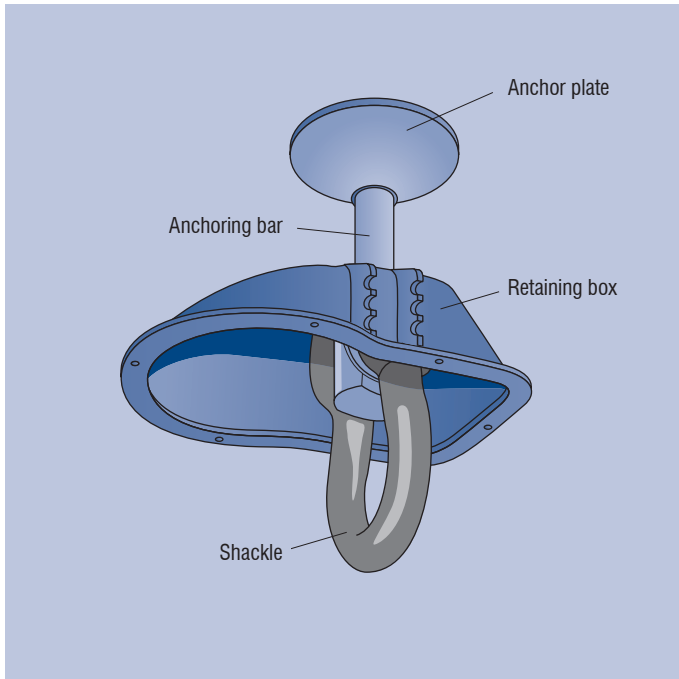

The system components of the PFEIFER load eye are:

- Retaining box
- Shackle
- Anchoring element (anchoring bar and plate)
- Identification label



The anchor system is supplied complete. Separate components cannot be ordered separately.



Warning: The installation of incomplete load eyes is not permitted! Missing components must be replaced only by the manufacturer. The use of parts that are not part of this system can result in reduced safety levels including failure of the load eye. This is a hazard for the life and limb of the people working on the installation. Check for completeness before use.



Caution: The PFEIFER load eye must not be allowed to come into contact with chemical products or other aggressive substances.

Safety

In accordance with machinery directive 2006/42/EC the following working coefficients were implemented:

- Metallic components: $\gamma=4$
- Anchorage in concrete of quality C 25/30: $\gamma=4$

The load eye was tested for its fitness as an attachment for personal safety equipment in the context of dynamic fall tests. The tests were carried out in accordance with DIN EN 795:2012, in which the falling of three persons was simulated.



Warning: The responsible planner must provide proof of the sufficient load capacity of the manhole cover.

Use

The PFEIFER load eye is designed for installation into flat steel-reinforced concrete slabs of a minimum quantity of C25/30. In this they serve as

- 1) Attachment points for the temporary attachment of material loads during assembly and maintenance work.
- 2) Attachment point for personal fall-safety equipment.

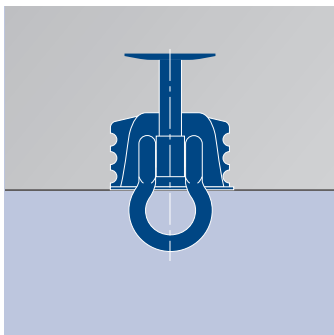

Notice: The transport of passengers is not intended.



Notice: Only use the system if you are trained in safe handling. If you have any doubts about the safe condition of the system, the question of usability must be assessed by a suitably authorised person.



Warning: Use of the anchor by untrained personnel results in the risk of incorrect use and the risk of items falling down, causing a hazard to life and limb of persons. Use only trained personnel!



Warning: The attachment point can be used either for the temporary attachment of material loads or for personal safety equipment. It is not permitted to use for both purposes simultaneously.

Installation instructions for PFEIFER load eye

Attachment point for load attachment devices, satisfying EC machinery directive 2006/42/EC
Attachment point for personal safety equipment Z-14.9-778



PFEIFER

Fixing Systems
Lift Installation

Installation

Installation of the PFEIFER load eye is as shown in the following drawings:

- 1) The boxes are mounted in the formwork before the concrete is poured by simply nailing or gluing them securely in position. When gluing it must be ensured that the cover engages firmly in the retaining box so that its position cannot change.
- 2) Pour the concrete carefully and pay attention to the components. Carefully compact the concrete, avoiding direct contact between vibrator and load eye or retaining box and anchor
- 3) Demoulding: carefully remove the formwork. Avoid causing damage!
- 4) Remove the fixing nails
- 5) Remove the cover of the retaining box
- 6) Pull the shackle out of the retaining box and place it in the desired position

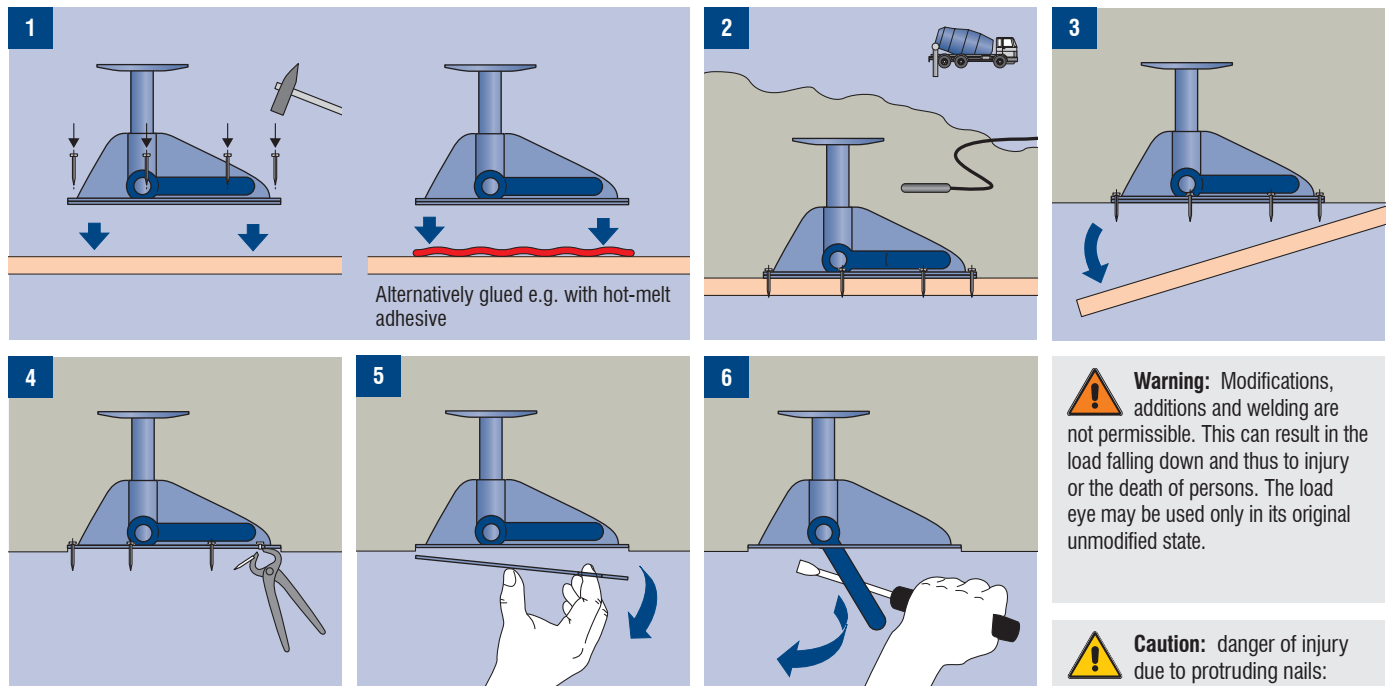

Warning: Modifications, additions and welding are not permissible. This can result in the load falling down and thus to injury or the death of persons. The load eye may be used only in its original unmodified state.

Caution: danger of injury due to protruding nails: always work with appropriate care and protective equipment.

Caution: Do not load the PFEIFER load eye before the concrete has reached a sufficient strength. The required minimum cube compressive strength $f_{ck,cube} = 30 \text{ N/mm}^2$.

Dimensioning

The selection of the load eye and the dimensioning of the reinforced concrete ceiling with a minimum concrete quality C 25/30 into which the load eyes will be installed must be done by a qualified engineer. The basis for this calculation must be the approval of the German Institute of Building Technology Z-21.8-2030 or Z-14.9-778.

To ensure that the force to be anchored is applied locally to the concrete with sufficient safety, certain minimum axis and edge distances must be maintained. In addition, minimum requirements for component thicknesses are specified in order to protect against corrosion. The minimum dimensions are given in Table 1 and, in each case, refer to the longitudinal axes of the anchors.

A concrete coverage c_{nom} of 20 mm for the anchor plate and surface reinforcement was assumed when defining the minimum component thickness. Depending on the particular operational and environmental conditions, it may be necessary in certain cases to adjust the concrete coverage and hence the component thickness in accordance with BS EN 1992-1-1, Section 4.

For taking up the material loads the minimum reinforcement is to be installed in the lower position in accordance with Table 1.

Caution: The anchorings must be designed in line with engineering practice. Verifiable calculations and design drawings must be prepared, which take into account the loads to be anchored

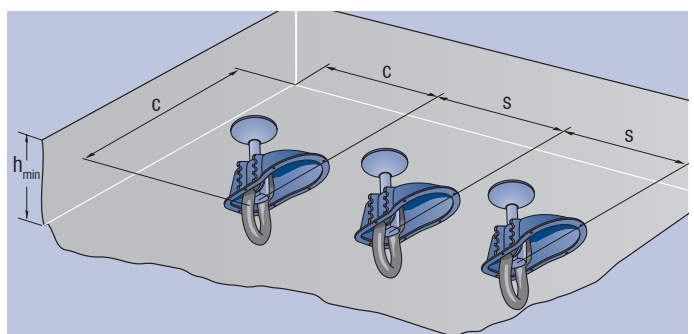

Table 1 - Minimum dimensions

Carrying capacity kg	Edge distance c mm	Minimum spacing s mm	Minimum component thickness h_{min} mm	The minimum surface reinforcement is mm^2/m
2000	250	500	150 (130*)	400
4000	350	700	220 (200*)	(Ø10/200)

* If the anchor plate is coated with a suitable corrosion protection system, this reduced coverage thickness can be used. The required proofs are to be furnished by the user.

Instructions for use of PFEIFER load eye (including testing logbook)

Attachment point for load attachment devices, satisfying EC machinery directive 2006/42/EC
Attachment point for personal safety equipment Z-14.9-778



PFEIFER

Fixing Systems
Lift Installation

Use

PFEIFER load eyes are attachment points for the temporary attachment of material loads during assembly or maintenance work. They are intended for top-sided installation in steel reinforced concrete ceilings.

The load eye is designed to accommodate loads resulting from planned straight pull.

Warning: The load eyes are not suitable for the transport of persons or for use as fall protection!

Caution: Before the attachment device is used for the first time, the operating company must ensure that it enters service only after it has been examined by a suitably qualified technician and any faults discovered have been rectified.

Caution: All instructions for the use and application of any other products that are used in connection with the PFEIFER Hoisting ring must be followed.

Warning: The attachment point can be used for one at a time of the two optional applications (Option A or B) according to the table on the right. It is not permitted to attach loads and personnel at the same time!

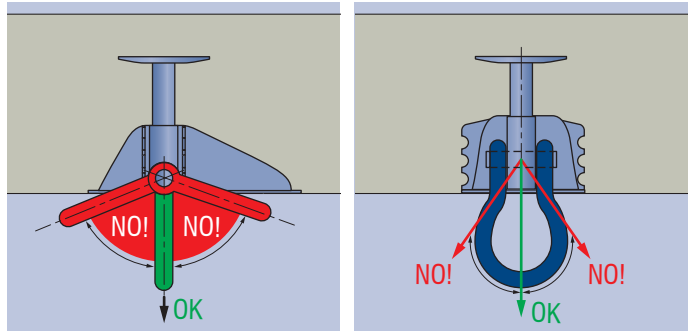

Load eye	Co- lour	Carrying capacity Option A : Attachment point for load suspension device	Carrying capacity Option B: Attachment point for personal safety equipment
20	blue	2000 kg	3 persons
40	red	4000 kg	3 persons

Tests

Tests are to be performed as described below and recorded in the test log book. When the test criteria are no longer met, the PFEIFER hoisting loop can no longer be used.

Regular inspection Inspection prior to use

The contractor or operating company is responsible for ensuring that the PFEIFER load eye is inspected at regular intervals. Whenever the anchor is used, it must first be verified that the last inspection and confirmation of its usability took place not longer than 12 months earlier. Depending on the operational conditions (frequency of use, environmental influences), inspections may also be necessary at shorter intervals. The inspection tests must always be conducted by suitably qualified persons.

Extraordinary inspection

The contractor or operating company must ensure that the PFEIFER load eye undergoes a special inspection test by a suitably qualified person after any

unusual incident that could affect its carrying capacity. Written authorisation by a suitably qualified person is also required before using the attachment device after it has undergone repairs.

Inspection criteria

Caution: The attachment point must be in a good operating condition and undamaged. Signs of corrosion, visible distortions, wears or deformations are unacceptable.

Caution: The shaft ceiling, particularly the concrete, must be in sound condition. Any visible cracking, blow out or signs of corrosion are unacceptable.

Caution: Do not use an attachment point which has an unreadable or missing identification label.

Disposal

Notice: The respective load eye must be marked clearly and unmistakably immediately after determination of the discarding time. If necessary the load eye is to be removed and disposed of properly.

Notice: Before disposal (steel scrap) the load eye must be rendered unusable in order to reliably prevent further use.

Identification mark



Colour of the retaining box:

Hoisting ring	Colour
20	blue
40	red

Instructions for the use of the PFEIFER load eye

Attachment point for load attachment devices, satisfying EC machinery directive 2006/42/EC



PFEIFER

Fixing Systems

Lift Installation

Testing logbook

Year of manufacture:	Date of first use:
Purchase date:	Batch number:

Date	Reason for editing (regular inspection or repair)	Damage found, repairs done, etc.	Name / signature of qualified person	Date of the next regular inspection

PFEIFER SEIL- UND HEBETECHNIK GMBH
Dr.-Karl-Lenz-Straße 66 · 87700 Memmingen
Fon +49 (0)8331-937-290, Fax +49 (0)8331-937-342
Email bautechnik@pfeifer.de · Internet www.pfeifer.de

PFEIFER load eye 20/40 – attachment point for personal safety equipment

Assembly documentation form (example)



PFEIFER

Fixing Systems
Lift Installation

Project

Street: _____ Building: _____

Postcode/Town: _____ Storey: _____

Client

Street: _____ Contact person: _____

Postcode/Town: _____ Telephone / mail: _____

Assembly firm

Street: _____ Assembler: _____

Postcode/Town: _____ Telephone / mail: _____

Installation parameters

Structural element: _____ Installation plan: _____

Load eye type: _____ Concrete quality: _____

Part thickness: _____ Reinforcement: _____

Edge distance: _____

Date of completion: _____

We hereby confirm that the PFEIFER load eye as the attachment point for personal safety equipment has been fitted correctly with respect to all details and with due consideration of all regulations of Z-14.9-778 of the Deutsche Institut für Bautechnik.

Place, date

Signed, company stamp

(A copy of this certificate will be issued to the client and the responsible construction firm for submission to the relevant building authorities if required.)



EC Declaration of Conformity

according to the EC machinery directive 2006/42/EC, appendix II 1A

The manufacturer

PFEIFER Seil- und Hebeteknik GmbH
Dr.-Karl-Lenz-Straße 66
D-87700 Memmingen

declares that the attachment points for lifting devices with the designations PFEIFER Load eye 20 and PFEIFER Load eye 40 as per article 2d) are, on the basis of their design and construction, compliant with the requirements of the **directive 2006/42/EC of the European Parliament and the Council of 17 May 2006 concerning machines and with the amendment to the directive 95/16/EC** (in short: EC machinery directive 2006/42/EC).

Applied harmonised standards

- EN ISO 12100:2011-03
Safety of machinery - general design principles - risk assessment and risk reduction

Other applied standards or specifications

- CUAP 06.01/15
Common Understanding of Assessment Procedure for a European Technical Approval according to Article 9.2 of the construction Product Directive
Steel plate with cast-in anchor(s)
Final Version of March 2003
- DIN CEN/TS 1992-4-2
Design of fastenings for use in concrete
Part 4-2: Head bolt
Edition: August 2009
- BS EN 1090
Eurocode: Basis of structural design
- BS EN 1992 Eurocode 2: Design of concrete structures
- BS EN 1993 Eurocode 3: Design of steel structures
- General Building Authority Approval Z-21.8-2030 PFEIFER load eye 20/40

The person responsible for the creation and maintenance of the technical documentation is

- Herr Dipl.-Ing. Christoph Neef
Technical Manager, Connecting and Lifting Systems, PFEIFER Seil- und Hebeteknik GmbH

PFEIFER Seil- und Hebeteknik GmbH
Memmingen, 12.06.2014

Dipl.-Ing. Matthias Kintscher
Manager, Business Area Connecting and Lifting Systems

Dipl.-Ing. Christoph Neef
Technical Manager, Connecting and Lifting Systems