

Instructions for installation and use PFEIFER LSG Lifting Loop for through- hole fitting

Attachment point for load attachment devices, satisfying EC machinery directive 2006/42/EC



PFEIFER

Fixing Systems
Lift Installation

PFEIFER LSG lifting loops are for later fitting, away from the edges, in the ceiling lower surfaces of lift shafts. They are only to be used for temporary suspension of lift cabins or other items during installation or maintenance work. They may not be used for transporting people, nor for attaching fall arrest systems.

Material:

Socket made of special grade precision steel tube, galvanized
pressed and with threaded rod
flexible steel cable, galvanized
Flat steel, galvanized
Hexagon nuts, galvanized

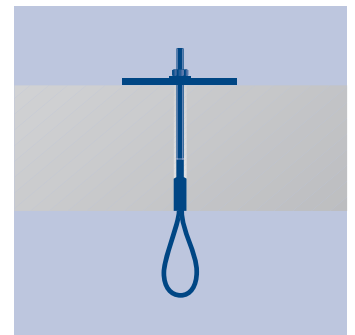
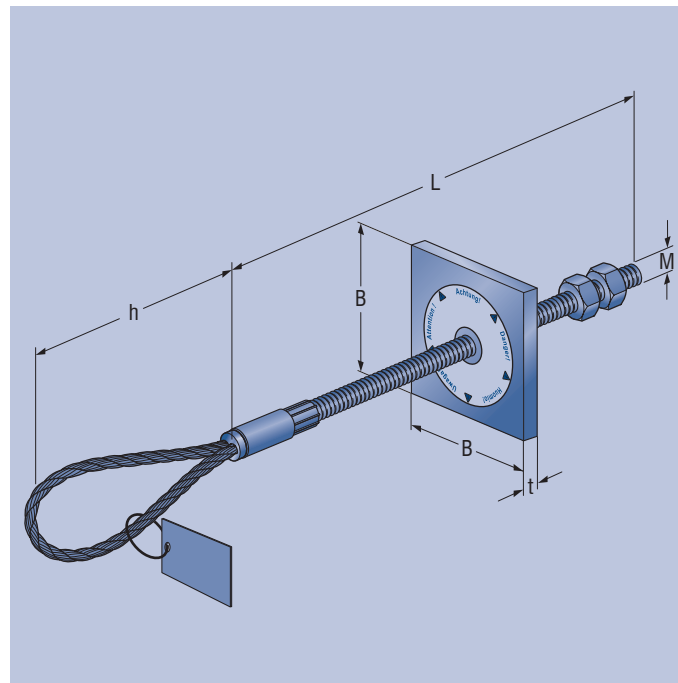

Order no.	Carrying capacity kg	WLL kN	M	L	Dimensions in mm		t	Weight kg/each
					h	B		
248819	500	5	8	525	135	100	10	1,05
248364	1000	10	12	530	130	120	12	1,9
248938	1750	17,5	16	540	180	120	12	2,5
248939	2500	25	20	550	215	160	12	4,8
248940	4000	40	20	555	245	200	15	7,8

Example order for 10 PFEIFER LSG Lifting Loops with load capacity of 1000 kg / WLL 10 kN:
10 PFEIFER LSG Lifting Loops; WLL 10 kN, Ref. no. 248364

Instructions for installation and use of PFEIFER LSG Lifting Loop

Attachment point for load attachment devices, satisfying EC machinery directive 2006/42/EC

System

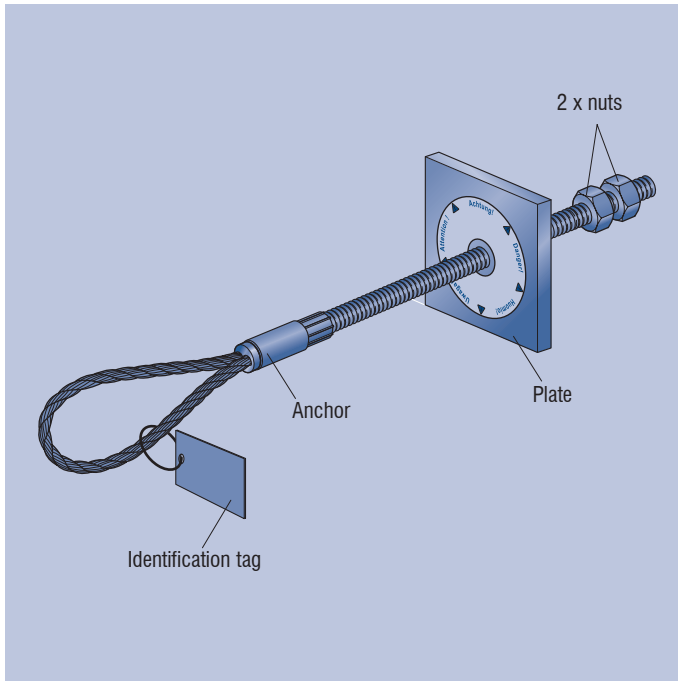

The system components of the PFEIFER LSG Lifting Loop are:

- Threaded socket pressed and with threaded rod
- Wire rope loop secured against unscrewing
- Anchor plate with central hole
- 2 hexagon nuts (nut / lock nut)
- Identification tag
- Label on both sides

i The anchor system is supplied complete. Separate components cannot be ordered separately.

Warning: The use of incomplete anchors is not permissible. Missing components must be replaced only by the manufacturer. The use of parts that are not part of this system can result in reduced safety levels including failure of the anchor and falling of the building component. This is a hazard for the life and limb of the people working on the installation. The anchor system must be checked for completeness before use.

Caution: The PFEIFER LSG Lifting Loop must be kept away from contact with chemical products or other aggressive substances.

Sicherheit

In accordance with machinery safety directive 2006/42/EC the following working coefficients were implemented:

- Working coefficient of all metal components: $\gamma=4$
- Working coefficient of the cables: $\gamma=5$
- The dimensions of the plate shown are chosen such that the local compression can be taken with a safety factor of 4 for concrete of grade C20/25 and up.

Warning: Certification of adequate carrying capacity of the shaft ceiling (thickness, reinforcement, load transmission) is to be provided by the responsible planner.

Anwendung

PFEIFER LSG load loops are attachment points for load attachment devices. They are intended for later flat fitting mainly in lift-shaft ceilings of reinforced concrete. They serve as load connection point for the temporary attachment of objects during assembly and maintenance work.



Notice: Only use the system if you are trained in safe handling. If you have any doubts about the safe condition of the system, the question of usability must be assessed by a suitably authorised person.

Warning: Use of the anchor by untrained personnel results in the risk of incorrect use and the risk of items falling down, causing a hazard to life and limb of persons. Use only trained personnel.

Warning: The attachment point for load attachment devices is provided for the attachment of objects. It is not intended as an attachment point for protection of people against falls from a height or for transporting people.

Installation instructions for PFEIFER LSG Lifting Loop

Attachment point for load attachment devices, satisfying EC machinery directive 2006/42/EC



PFEIFER

Fixing Systems
Lift Installation

Installation

Installation of the PFEIFER LSF Lifting Loop is as shown in the following drawings:

- 1) Make the hole
- 2) Push the anchor into the hole and provide temporary means to prevent it from falling out. The entire anchor socket must be enclosed – only the wire rope loop may protrude.
- 3) Pouring the flowable material (e.g. manufacturer PAGEL®) into the cavity.
- 4) Put the plate over the protruding thread end from above and screw on the nut hand-tight.
- 5) Then secure the nut with a lock nut and high-strength thread locking compound to prevent accidental unscrewing.
- 6) If necessary, remove surplus threaded rod at least 1 cm above the lock-nut.

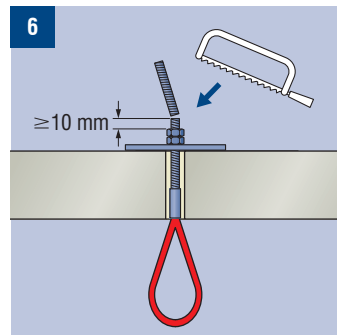
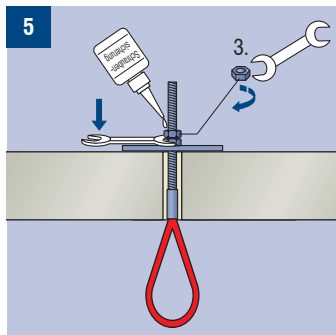
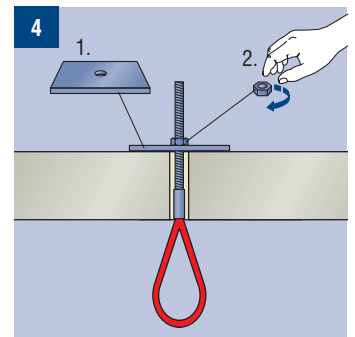
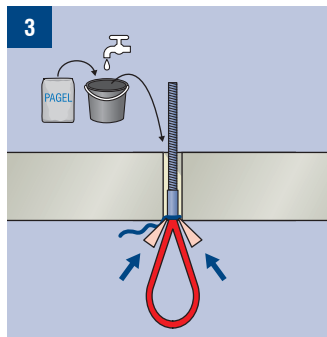
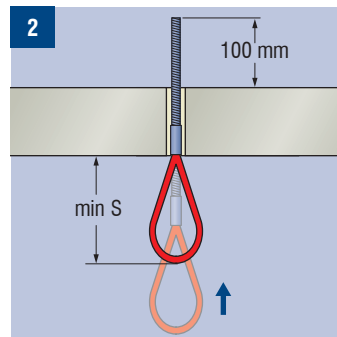
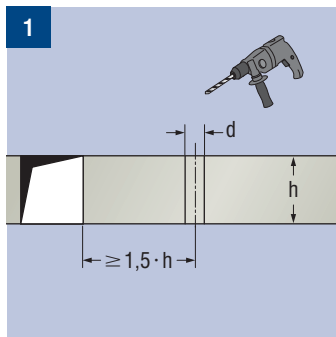

Table 1:

WLL [kN]	d [mm]	minS [mm]
5	16	135
10	22	130
17,5	28	180
25	32	215
40	40	245

Warning: All modifications, additions and welding work are prohibited. This can result in the load falling down and thus to injury or the death of persons. The LSG lifting loop box must be used only in its original unmodified state.

Caution: Do not load the PFEIFER LSG Lifting Loop before the concrete has reached a sufficient strength. The required minimum concrete compressive strength is $f_{ck,cube} = 25 \text{ N/mm}^2$.

Note: the two nuts must be fixed with a high-viscosity, high-strength, ideally coloured thread locking compound (e.g. WEICON-LOCK AN 302-72 or equivalent). This makes accidental unscrewing more difficult!

Dimensioning

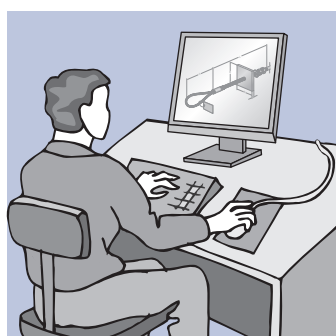

Dimensioning the anchors is the responsibility of the planner concerned. In particular, the load transmission through the anchor plate into the reinforced concrete ceiling and its further transmission must be individually verified.

Caution: The planning must be done only by qualified engineers.

Instructions for use of PFEIFER LSG Lifting Loop (including testing logbook)

Attachment point for load attachment devices, satisfying EC machinery directive 2006/42/EC



PFEIFER

Fixing Systems
Lift Installation

Use

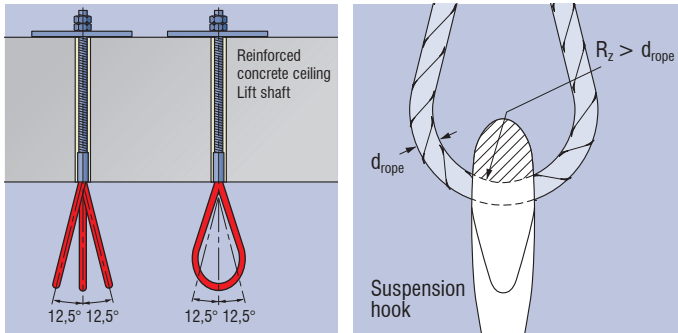

PFEIFER LSG lifting loops are for later fitting, away from the edges, in the ceiling lower surfaces of lift shafts. They are only for temporary suspension of the lift cabin or other objects during installation or maintenance work, always without transporting people and never to protect against falling. In selecting the attachment device, the corner radii R_z as in Table 2 must be observed. The LSG lifting loop is intended for taking loads resulting from straight pull. Planned loads due to skew pull $\geq 12.5^\circ$ must be avoided.

Caution: Before the attachment device is used for the first time, the operating company must ensure that it enters service only after it has been examined by a suitably qualified technician and any faults discovered have been rectified.

Caution: All instructions for the use and application of any other products that are used in connection with the PFEIFER LSG Lifting Loop Box must be followed.

Table 2:

WLL [kN]	R_z [mm]
5,0	10
10,0	12
17,5	15
25,0	17
40,0	22

Warning: Too small a corner radius R_z of the attachment device can result in failure or damage of the cable loop even at the rated load. Use only attachment devices with corner radius at least R_z .

Tests

Tests are to be performed as described below and recorded in the testing logbook. When the test criteria are no longer met, the PFEIFER LSG lifting loop can no longer be used.

Regular inspection

Inspection prior to use

The contractor or operating company is responsible for ensuring that the PFEIFER Lifting Loop LSG is inspected at regular intervals. Whenever the anchor is used, it must first be verified that the last inspection and confirmation of its usability took place not longer than 12 months earlier. Depending on the operational conditions (frequency of use, environmental influences), inspections may also be necessary at shorter intervals. The inspection tests must always be conducted by suitably qualified persons.

Extraordinary inspection

The contractor or operating company must ensure that the PFEIFER LSG Lifting Loop undergoes a special inspection test by a suitably qualified person

after any unusual incident that could affect its carrying capacity. Written authorisation by a suitably qualified person is also required before using the attachment device after it has undergone repairs.

Inspection criteria

Caution: The attachment point must be in a good operating condition and undamaged. Broken wires, signs of corrosion, visible distortions or deformations are unacceptable.

Caution: The shaft ceiling, particularly the concrete, must be in sound condition. Any visible cracking, blow out or signs of corrosion are unacceptable.

Caution: Do not use an attachment point which has an unreadable or missing identification label.

Disposal

Notice: As soon as the anchor is seen to be ready for scrapping, it must be clearly and unmistakably marked as such. After their removal from installation and until they are scrapped, anchors marked like this must be stored in a special temporary store.

Notice: Before scrapping (steel scrap), the anchor or cable loop must be rendered unusable (cut off the threaded rod, cut the cable etc.) to ensure it cannot be re-used.

Identification mark

PFEIFER LSG Lifting Loop

Type / ID no: 000000/PPPPPP
Year of manufacture: 2012

PFEIFER

PFEIFER Seil- und Hebeteknik GmbH
Dr.-Karl-Lenz-Strasse 66
D-87700 Memmingen

Load attachment point

1200 kg

CE 2006/42/EG



Usage instructions for PFEIFER LSG Lifting Loop

Attachment point for load attachment devices, satisfying EC machinery directive
2006/42/EC

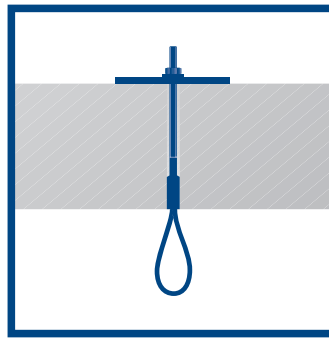

Fixing Systems
Lift Installation

Testing logbook

Year of manufacture:	Date of first use:
Purchase date:	Batch number:

Date	Reason for action (regular inspection or repair)	Damage seen, repairs done etc.	Name / signature of qualified person	Date of next regular inspection

EC declaration of conformity according to the EC machinery directive 2006/42/EC, appendix II 1A

The manufacturer **PFEIFER SEIL- UND HEBETECHNIK GMBH**
DR.-KARL-LENZ-STRASSE 66
D-87700 MEMMINGEN

declares that the following lifting device according to article 2 d) with the

product designation **PFEIFER LSG Lifting Loop (for through-bolted installation)**
in the sizes: **0.5 t; 1.0 t; 1.75 t; 2.5 t; 4.0 t**

conforms to the regulations contained in the directives listed below on account of its design and construction
– EC machinery directive 2006/42/EC

Applied harmonised standards

– DIN EN ISO 14121-1:2007-12
Safety of machinery – Risk assessment - Part 1: General principles

The person responsible for the creation and maintenance of the technical documentation is

– Mr. Dipl.-Ing. Christoph Neef
Manager, Development Connecting and Lifting Systems, PFEIFER Seil- und Hebetchnik GmbH

PFEIFER Seil- und Hebetchnik GmbH
Memmingen, 10/12/2015

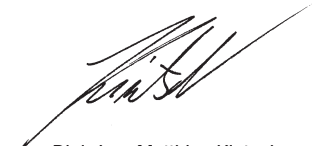

ppa. Dipl.-Ing. Matthias Kintscher
Manager, Business Area Connecting
and Lifting Systems



i. V. Dipl.-Ing. Christoph Neef
Manager, Development Connecting and Lifting Systems