

Punching Shear Reinforcement



JORDAHL® Punching Shear Reinforcement JDA

For Everyone Who Needs More Space in Less Time.

Technical Information

Quality since 1907.



JORDAHL's registered office and administrative headquarters on the premises of its affiliate PUK

The JORDAHL Company

JORDAHL connects: concrete, steel, heavy loads and a whole lot more. And of course numerous customers around the world who have already decided to use high-quality and individual products from fastening, reinforcement, connection, and mounting technology and facade connection systems. Customers who choose JORDAHL want more – higher quality, broader choice,

better technical advice, wider experience. The company was founded in Berlin in 1907 and since that time we have been at the forefront of connection and reinforcement technology development. JORDAHL products such as anchor channels have become milestones in the evolution of structural engineering and have brought lasting changes to construction, shaping the way buildings are designed and making them safer, not just in Germany.

The JORDAHL Seal

JORDAHL has over 100 years of unique experience in the market. This experience forms the basis of our expertise and high standards. Whether high-quality products, service or consulting – we aim to do everything for our customers to the same demanding standard of excellence. This is what the JORDAHL seal stands for. It is a guarantee of quality for our customers and also the standard that we strive to adhere to each and every day.



The sign of excellent JORDAHL® Quality.

The Invention of the Kahn Steel Reinforcement System

The German-born structural engineer Julius Kahn revolutionised construction with concrete with the invention of the Kahn steel reinforcement system – a steel reinforcement system with connecting stays or side "wings". Using these, his brother Albert Kahn, one of the most prominent industry architects of his time, erected a few of his spectacular structures. In 1907 the Kahn steel reinforcement system finally arrived in Europe: the Swedish structural engineer Ivar Kreuger had secured the European rights and on that basis, together with his friend, the Norwegian structural engineer Anders Jordahl, founded the company "Deutsche Kahneisen Gesellschaft Jordahl & Co." in Berlin. The Kahn steel reinforcement system, forerunner of today's punching shear reinforcement, became a successful product on the booming German construction market, and the foundation on which JORDAHL's success was built.

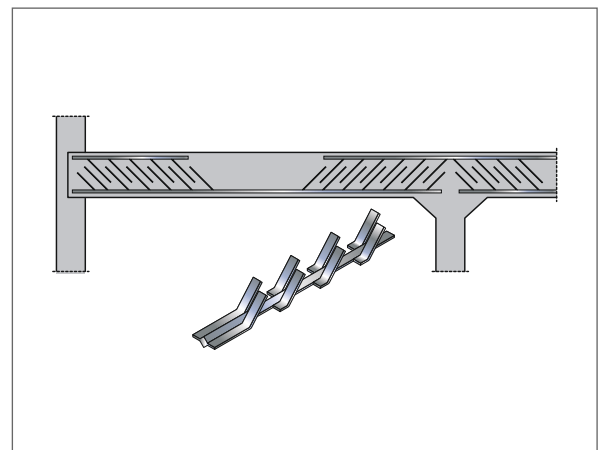

The Kahn steel reinforcement system

Contents

Introduction to Punching Shear Reinforcement	4
Advantages of the JORDAHL® Punching Shear Reinforcement JDA	5
Design According to ETA-13/0136	6 – 9
Summary of Proofs	6
Round Cut Guide	6
Design Load	7
Punching Shear Resistance without Punching Shear Reinforcement	7
Punching Shear Resistance with Double-Headed Anchors	8
Design in the Area C or 0.8 d	8
External Round Cut	8
Admissible Anchor Separations	9
Schematic Layout	10 – 12
Shared Standard Elements in Flat Slabs	10
Continuous Elements in Flat Slabs	11
Continuous Elements in Footings and Ground Slabs	12
Calculation Example	13
Design Software JORDAHL® EXPERT Punching Shear Reinforcement JDA	14 – 15
Installation	16 – 18
Installation in Site-Placed Concrete	17
Installation in Precast Plank / Topping Slabs	18
Standard Elements Product Range	19
Service	20
Fax Enquiry	21
Advice	23

All rights reserved.
The right to make revisions within the framework of product
and application-related, ongoing developments is reserved.

JORDAHL GmbH
Nobelstr. 51
12057 Berlin

Introduction to Punching Shear Reinforcement

Flat slab structures with large spans between supporting columns allow optimum use of factory or warehouse buildings with large floor space.

Even in the early days of concrete structures, the problem of punching shear at the column head area was already recognized (Fig. 1). Mushroom construction was introduced in around 1900 as a way of avoiding the arrangement with main transverse and auxiliary beams (Fig. 2).

Only a short time later the Kahn steel reinforcement system (Fig. 3) was used as tensile reinforcement. It possessed upturned wings which resisted transverse forces in the ceiling support area. The inventor of the Kahn steel reinforcement system, Julius Kahn, and his brother, the famous architect Albert Kahn, enjoyed great success with this product in the field of construction with reinforced steel concrete.

Using conventional methods it is often not possible to achieve thin slabs and wide spans between supporting columns or large slab breakthroughs close to the supporting column heads (Fig. 4). As an alternative, Andrä et al. have developed a solution in which the area at risk of punching shear is dowelled using dowel strips.

This solution was further developed for punching shear anchoring made from reinforcing steel with two swaged heads (Fig. 5) in each case. Following the introduction of the Eurocode, a fundamental reworking of the approval process became necessary. The current European Technical Approval ETA-13/0136 corresponds to the latest state of knowledge and is successfully applied in a number of areas.

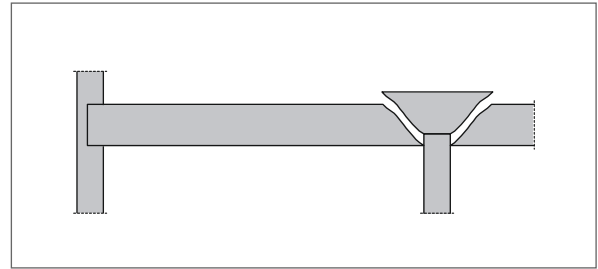

Fig. 1: punching shear situation

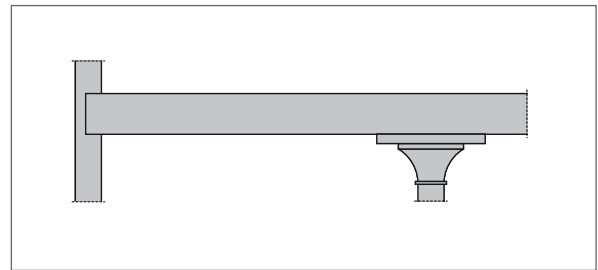

Fig. 2: mushroom ceilings

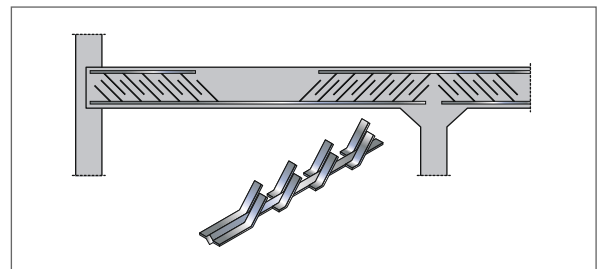

Fig. 3: "Kahn" steel reinforcement system

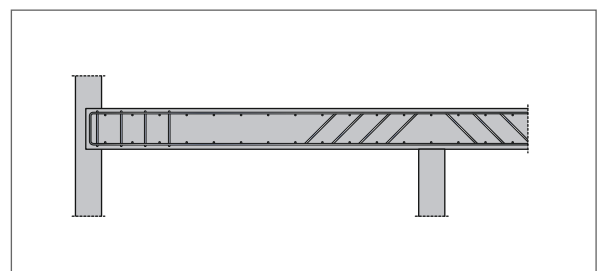

Fig. 4: flat ceiling with stirrups and bent-up rebar

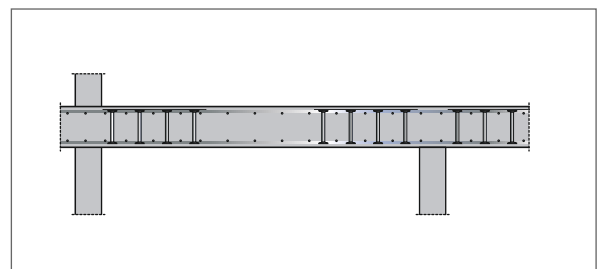

Fig. 5: JORDAHL® punching shear reinforcement JDA with double-headed anchors

Advantages of JORDAHL® Punching Shear Reinforcement JDA

For flat slab structures and foundations, JORDAHL® punching shear reinforcement JDA is used to transfer high transverse forces with low formwork and reinforcement requirements and also to optimise the use of space. The punching shear resistance can thus be increased by 50% when compared to foundations without punching shear reinforcement, even by 96% compared to ceiling slabs without punching shear reinforcement.

- European Technical Approval for static and dynamic effects (ETA-13/0136)
 - concrete strengths C20/25 to C50/60
 - design according to the safety concept of the Eurocode
 - asymmetrical load applications are accurately taken into account for all support positions
 - defined transition between punching shear and transverse force load-bearing capacity
 - increase in load-bearing capacity compared to flat slabs and foundations without punching shear reinforcement
 - suitable from a slab thickness of 18 cm
- level slab underside
 - unimpeded construction below the slab
 - optimum use of space
 - higher load-bearing capacity than conventional reinforcement techniques
 - low construction height of the concrete slabs
- simplified arrangement of the strips through arrangement of standard elements in a row
 - reduced formwork requirements
 - can be installed quickly and easily from above and below
 - flexible fabrication depending on static requirements

The JORDAHL® punching shear reinforcement JDA are made of double-headed anchors which are connected by a perforated connecting strip. The double-headed anchors secure the transition between punching shear and transverse load-bearing capacity.

Material

The double-headed anchors are made of B500B steel, and the perforated connecting strip is also made of structural steel.

Technical Information

JORDAHL® punching shear reinforcement JDA is manufactured according to the particular static requirements. The double-headed anchors are available in the following diameters: $d_A = 10, 12, 14, 16, 20$ and 25 mm (see page 19 for the product range). The head diameter d_k is always equivalent to 3 times the shaft diameter d_A . This ensures an essentially slip-free anchoring of the compression area and tensile area.

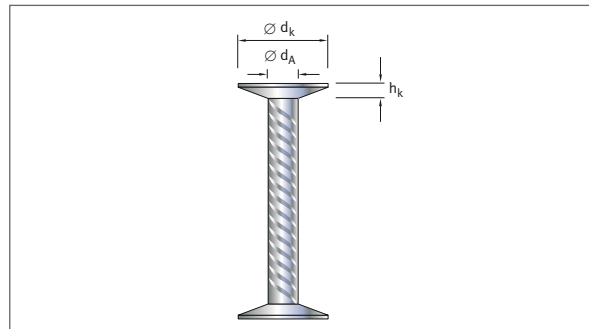

Double-headed anchor

Anchor diameter d_A [mm]	Head diameter d_k [mm]	Min. head thickness h_k [mm]	Anchor cross-section A [mm ²]	Load-bearing capacity F_{Rd} [kN]
10	30	5	79	34.1
12	36	6	113	49.2
14	42	7	154	66.9
16	48	7	201	87.4
20	60	9	314	136.6
25	75	12	491	213.4

Elements

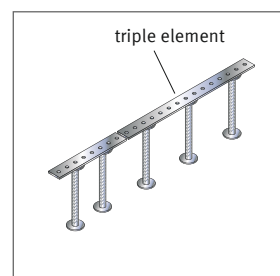

Optimised elements (piecewise)

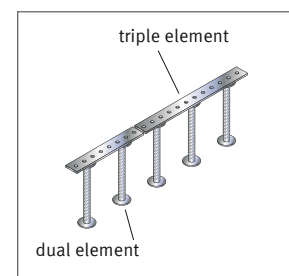

JDA standard elements (piecewise)

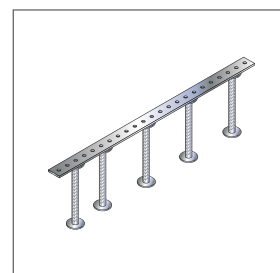

Optimised elements (continuous)

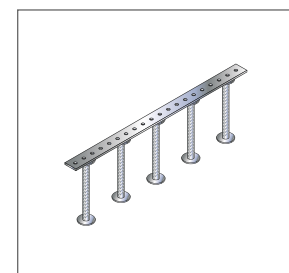

JDA standard elements (continuous)

Design According to ETA-13/0136

A fundamental of the design against punching shear is a clear separation of flat slabs and foundations. The

design is regulated in the European Technical Approval ETA-13/0136.

Summary of Proofs

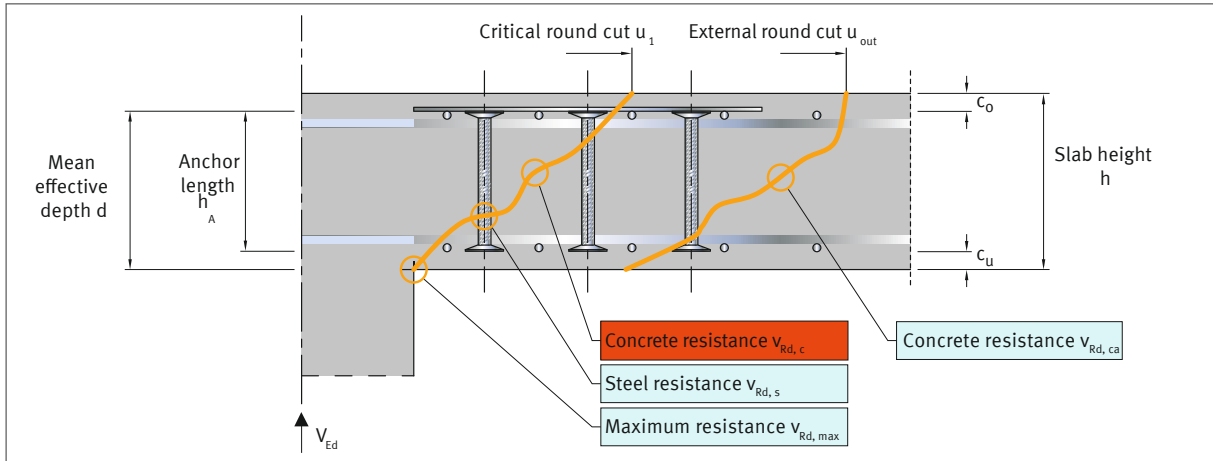

Round Cut Guide

For Flat Slabs

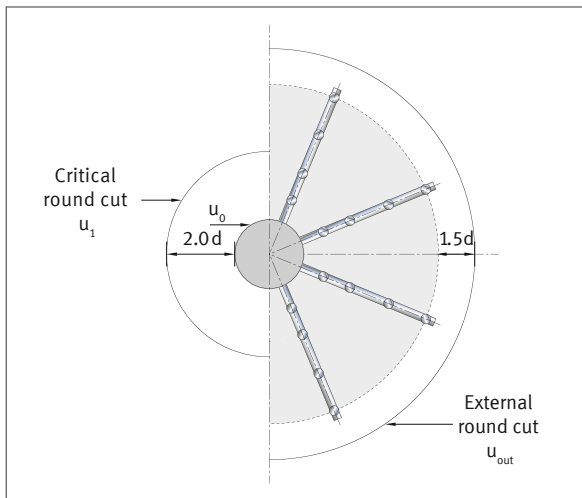

For Foundations

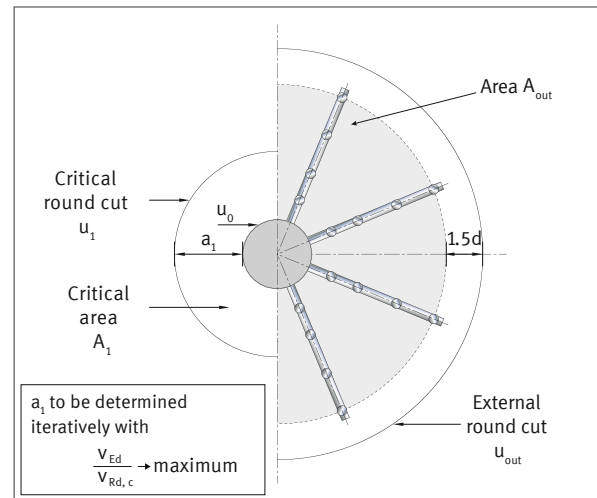

Conditions: $u_0 \leq 12d$
 $h \geq 180 \text{ mm}$
 $b \leq a \leq 2$ for rectangular supports

For edge and corner supports the round cut is guided perpendicularly to the free edge (cf. example on page

13). However, the smallest, critical round cut is decisive.

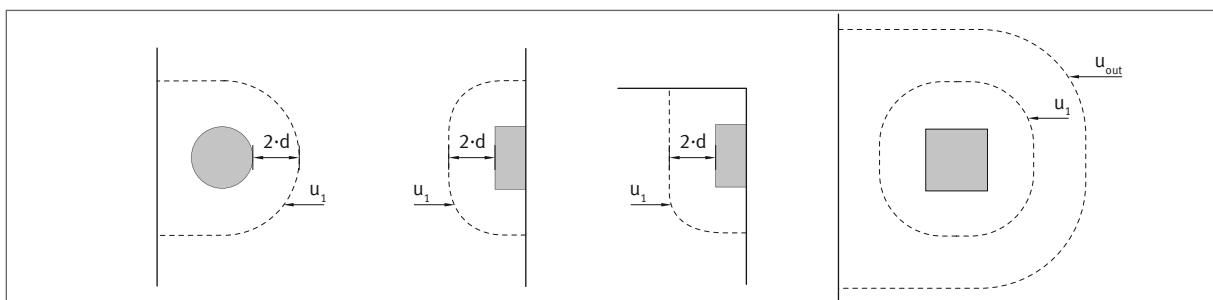

Design Load

For Flat Slabs

$$v_{Ed} = \frac{\beta \times V_{Ed}}{u_1 \times d} \quad [\text{N/mm}^2]$$

For Foundations

$$v_{Ed} = \frac{\beta \times V_{Ed,red}}{u_1 \times d} \quad [\text{N/mm}^2]$$

$$V_{Ed,red} = V_{Ed} - \sigma_{0d} \times A_1 = V_{Ed} \left(1 - \frac{A_1}{A_F} \right) \quad [\text{kN}]$$

σ_{0d} : soil pressure

A_F : contact area of the foundation; for foundation slabs the area delimited by the bending moment zero-points running in the radial direction

Load-Increase Factor

Simplified values are possible for support conditions for adjacent fields in the area $0.8 < l_1/l_2 < 1.25$.

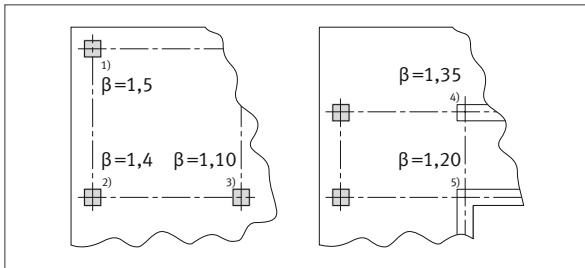

1) corner support, 2) edge support, 3) internal support, 4) wall end, 5) wall corner

Alternatively for a support span ratio of more than 25%, the more accurate process on the basis of a fully plastic shear stress distribution from EN 1992-1-1 can be used. The process with a reduced critical round cut is not admissible.

Punching Shear Resistance without Punching Shear Reinforcement

For Flat Slabs

$$v_{Rd,c} = C_{Rd,c} \times \kappa \times (100 \times \rho_l \times f_{ck})^{1/3} \geq v_{min} \quad [\text{N/mm}^2]$$

For Foundations

$$v_{Rd,c} = C_{Rd,c} \times \kappa \times (100 \times \rho_l \times f_{ck})^{1/3} \times \frac{2d}{a_1} \geq v_{min} \times \frac{2d}{a_1} \quad [\text{N/mm}^2]$$

$$\text{Size factor} \quad \kappa = 1 + \sqrt{\frac{200 \text{ mm}}{d}} \leq 2.0$$

$$\text{Longitudinal reinforcement ratio} \quad \rho_l = \sqrt{\rho_{lx} \times \rho_{ly}} \leq \begin{cases} 0.5 \times f_{cd}/f_{yd} \\ 0.02 \end{cases}$$

$$\text{Minimum resistance} \quad v_{min} = \frac{0.0525}{\gamma_c} \times \sqrt{\kappa^3 \times f_{ck}} \quad \text{for } d \leq 600 \text{ mm}$$

$$= \frac{0.0375}{\gamma_c} \times \sqrt{\kappa^3 \times f_{ck}} \quad \text{for } d > 800 \text{ mm}$$

Empirical Factor – For Flat Slabs

$$C_{Rd,c} = \frac{0.18}{\gamma_c} \quad \text{for } u_0 \geq 4d$$

$$C_{Rd,c} = \frac{0.18}{\gamma_c} \left(0.1 \times \frac{u_0}{d} + 0.6 \right) \geq \frac{0.15}{\gamma_c} \quad \text{for } u_0 < 4d$$

Empirical Factor – For Foundations

$$C_{Rd,c} = \frac{0.15}{\gamma_c} \quad \text{for compact foundations with } a_\lambda \leq 2.0 d$$

$$C_{Rd,c} = \frac{0.18}{\gamma_c} \quad \text{for slender foundations with } a_\lambda > 2.0 d$$

Punching Shear Resistance with Double-Headed Anchors

For Flat Slab

$$v_{Rd,max} = 1.96 v_{Rd,c} \text{ [N/mm}^2\text{]}$$

For Foundations

$$v_{Rd,max} = 1.50 v_{Rd,c} \text{ [N/mm}^2\text{]}$$

Design in Area C or 0.8 d

For Flat Slab

$$V_{Rd,sy} = m_c \times n_c \times \frac{d_A^2 \times \pi \times f_{yd}}{4 \times \eta} \text{ [kN]}$$

Slab thickness factor:

$h = 1.0$ for $d \leq 200$ mm

$h = 1.6$ for $d \geq 800$ mm

For Foundations

$$V_{Rd,sy} = f_{yd} \times A_{s,0.8d} \text{ [kN]}$$

$A_{s,0.8d}$: steel cross-sectional area of the double-headed anchors in the area 0.8 d

f_{yd} : design yield strength of the double-headed anchors

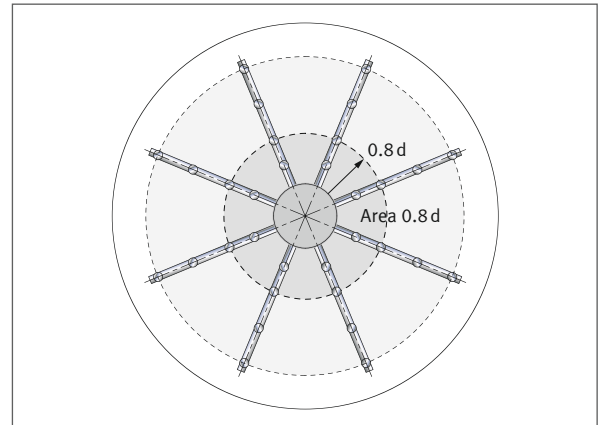
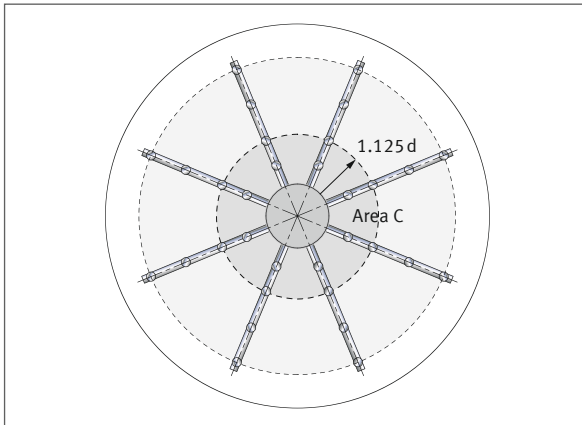

External Round Cut

$$v_{Rd,ca} = \frac{0.15}{\gamma_c} \times \kappa \times (100 \times \rho_l \times f_{ck})^{1/3} \geq v_{min} \text{ [N/mm}^2\text{]}$$

Reduced Load-Increase Factor:

Internal supports, wall ends, wall corners	Edge supports	Corner supports
$\beta_{red} = \beta \geq 1.10$	$\beta_{red} = \frac{\beta}{1.2 + \frac{\beta}{20} \times \frac{l_s}{d}} \geq 1.10$	$\beta_{red} = \frac{\beta}{1.2 + \frac{\beta}{15} \times \frac{l_s}{d}} \geq 1.10$

For Flat Slab

$$u_{out} = \frac{\beta_{red} \times V_{Ed}}{v_{Rd,ca} \times d}$$

For Foundations

$$u_{out} = \frac{\beta_{red} \times V_{Ed,red}}{v_{Rd,ca} \times d}$$

$$V_{Ed,red} = V_{Ed} \times \sigma_{od} \times A_{out} = V_{Ed} \left(1 - \frac{A_{out}}{A_F} \right) \text{ [kN]}$$

Admissible Anchor Separations

For Flat Slab

- the first anchor is located between $0.35 d$ and $0.5 d$ from the support
- the radial anchor spacing may not exceed $0.75 d$
- the maximum spacing of the anchors in the tangential direction at a spacing of $1.0 d$ from the support must be ≤ 1.7
- the tangential anchor spacing in area D may not exceed $3.5 d$

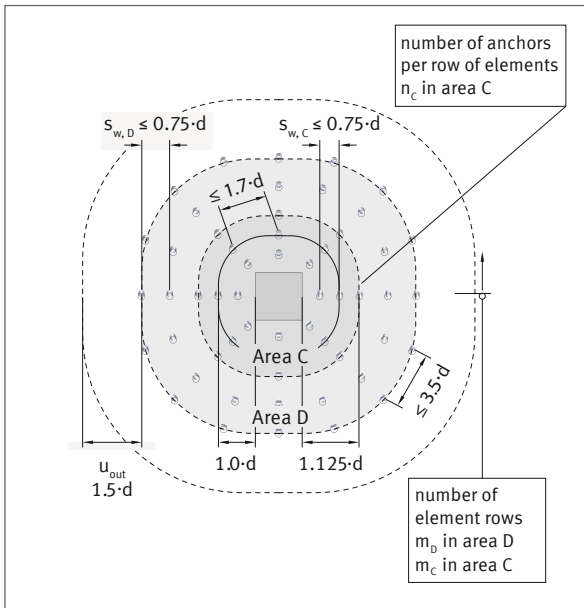

For Foundations

- the first anchor is located $0.3 d$ from the support, the second anchor $0.8 d$ from the support
- the radial anchor spacing may not exceed $0.75 d$ for slender foundations and $0.5 d$ for compact foundations
- the tangential anchor spacing may not exceed $2.0 d$

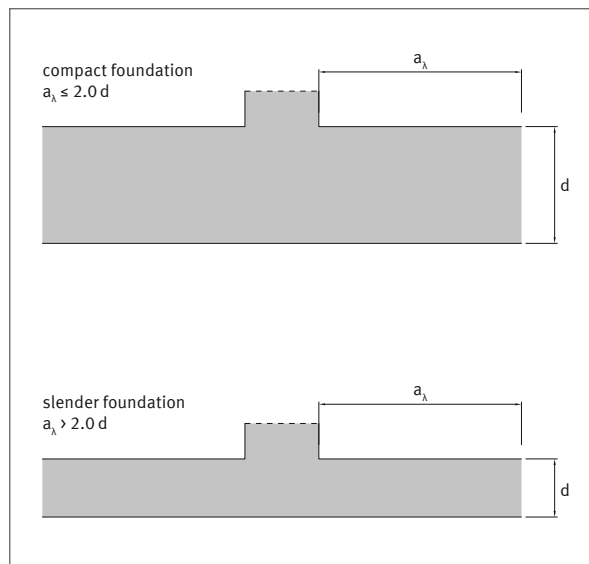
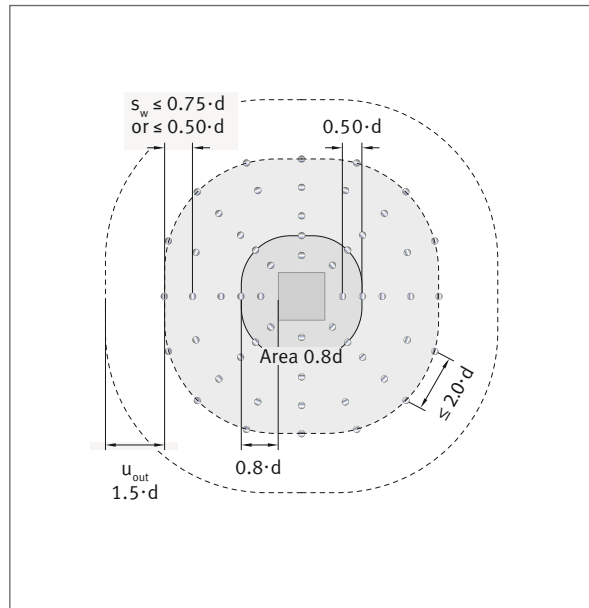

Schematic Layout

Shared Standard Elements in Flat Slabs

Piece-wise standard elements in flat slabs

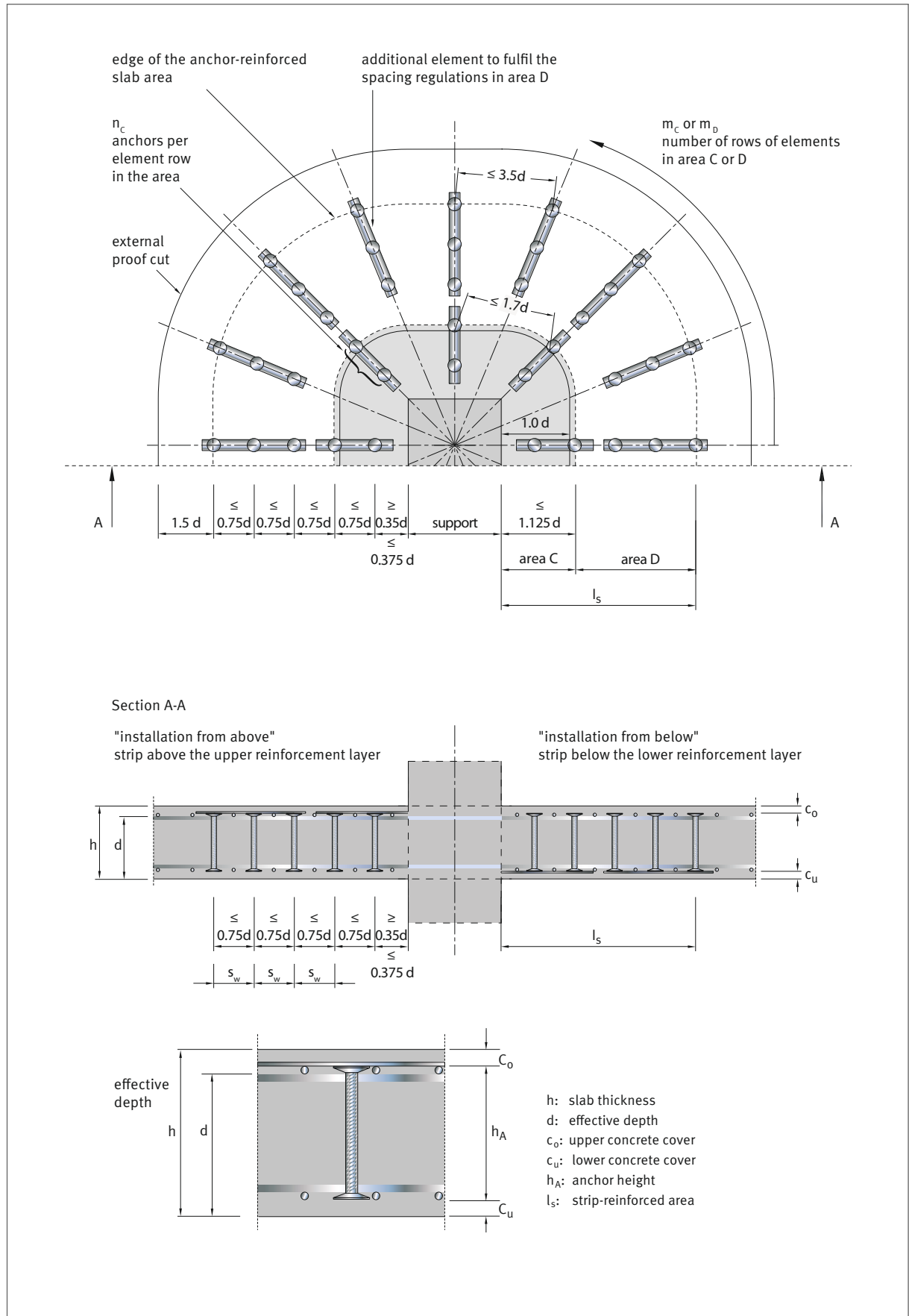

Continuous Elements in Flat Slabs

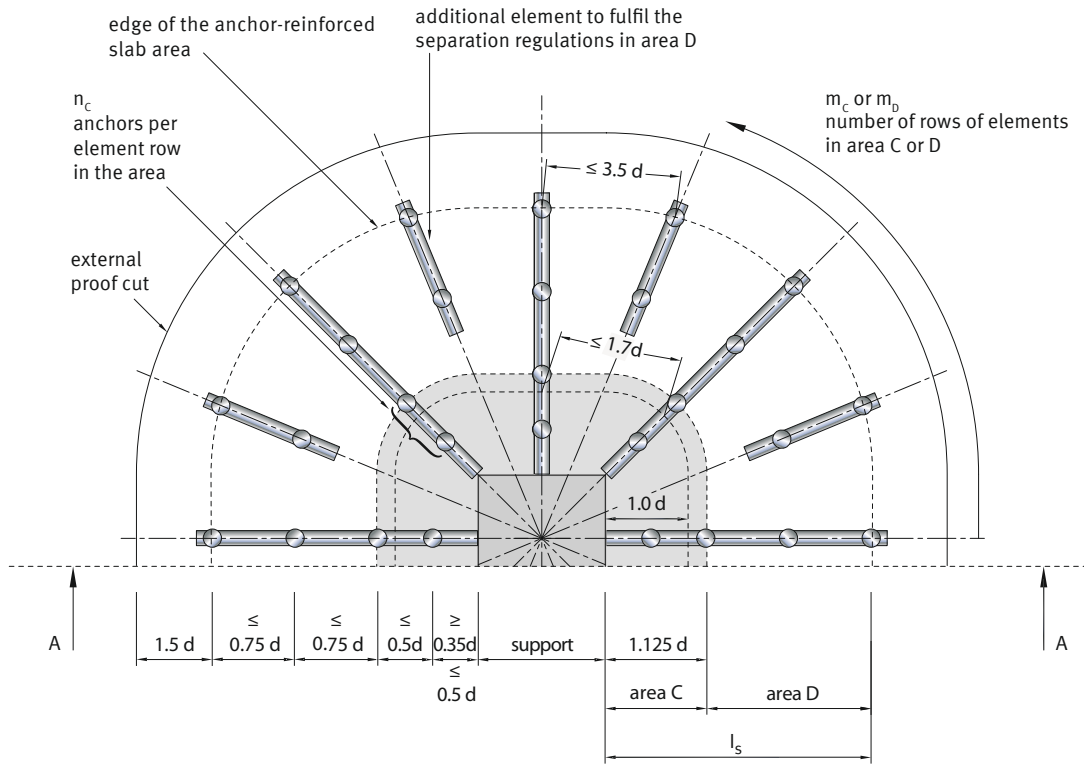

Section A-A

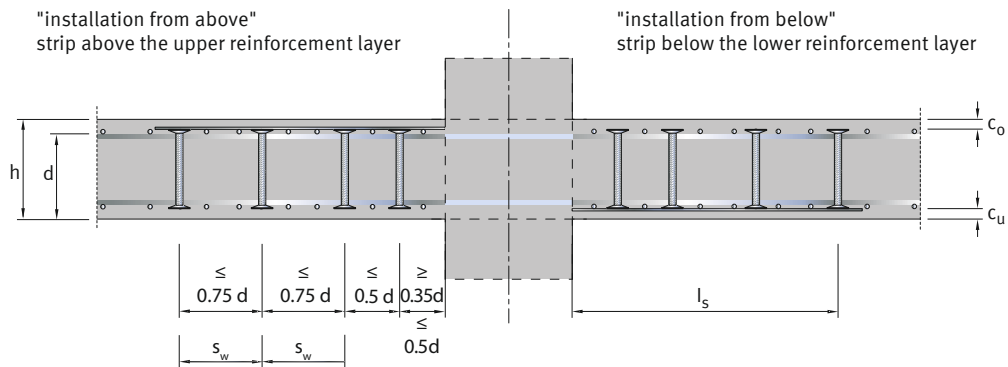

Continuous Elements in Footings and Ground Slabs

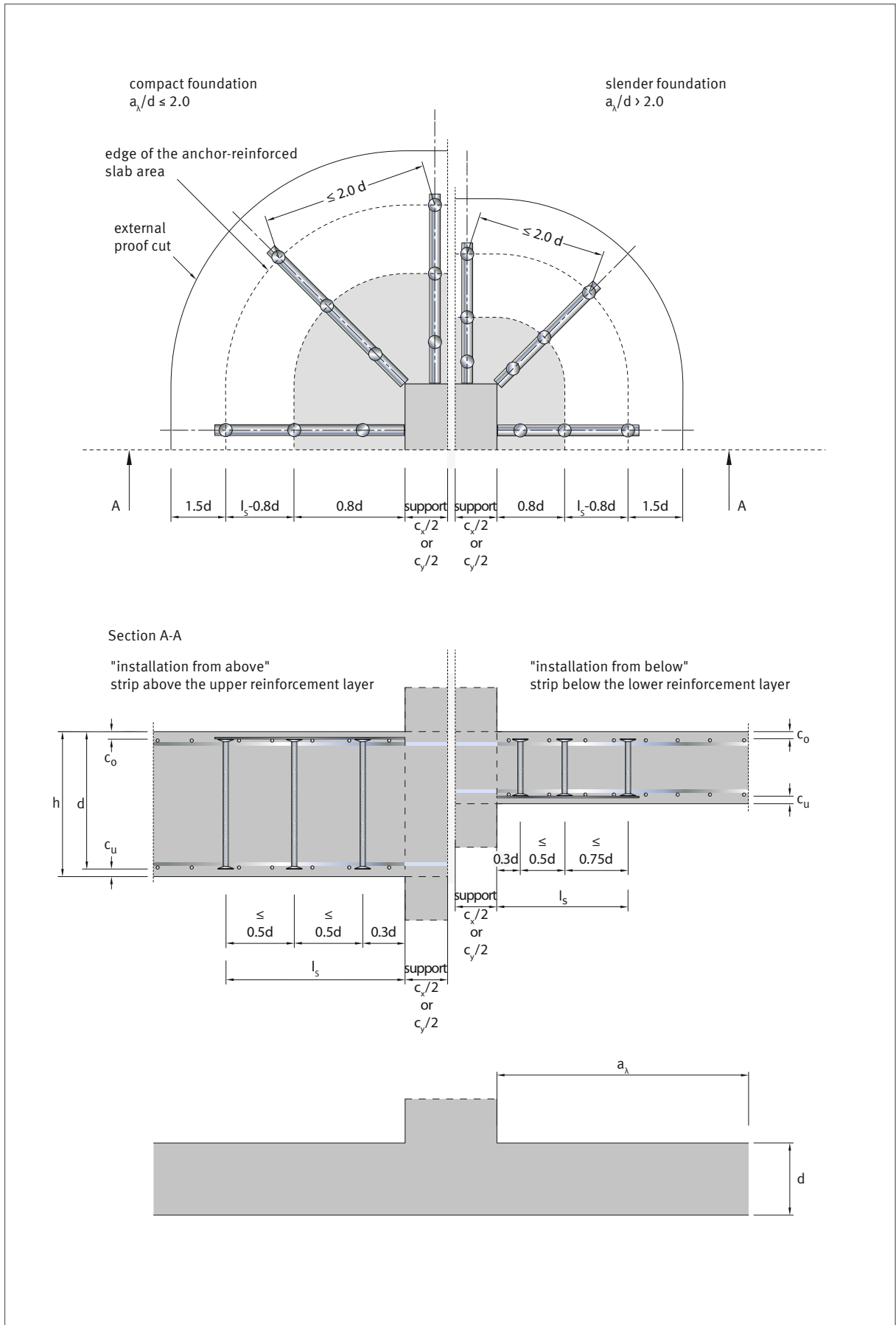

Calculation Example

1. Given values:

Slab height $h = 350$ mm
 Effective static depth $d = 305$ mm
 Concrete C35/45
 Reinforcement ratio $\rho = 1.0\%$
 Punching shear load $V_{Ed} = 800$ kN

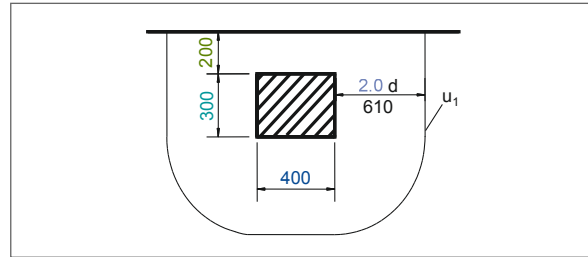

Round cut normal to the edge:

$$u_1 = 2 \times 300 + 400 + 2 \times 200 + 2.0 \times \pi \times 305 = 3316 \text{ mm} < 5233 \text{ mm}$$

Full round cut:

$$u_1 = 2 \times 300 + 2 \times 400 + 2 \times 2.0 \times \pi \times 305 = 5233 \text{ mm}$$

2. Punching shear verifications

2.1 Minimum resistance

$$v_{\min} = 1 / 1.50 \times \sqrt{(1.81^3 \times 35.00 \text{ N/mm}^2)} \times 0.0525 = 0.50 \text{ N/mm}^2$$

2.2 Critical round cut

$$v_{Ed} = 1.40 \times 800.00 \text{ kN} / (3316 \text{ mm} \times 305 \text{ mm}) = 1.11 \text{ N/mm}^2$$

$$v_{Rd,c} = \max [0.12 \times 1.81 \times (100 \times 0.0100 \times 35.00 \text{ N/mm}^2)^{1/3}; 0.50 \text{ N/mm}^2] = 0.71 \text{ N/mm}^2$$

$$v_{Rd,max} = 1.96 \times 0.71 \text{ N/mm}^2 = 1.39 \text{ N/mm}^2$$

$$v_{Ed} / v_{Rd,c} = 1.56 > 1$$

$$v_{Ed} / v_{Rd,max} = 0.80 \leq 1$$

JDA required

OK

2.3 Area C

$$\beta \cdot v_{Ed} = 1120.00 \text{ kN}$$

$$v_{Rd,sy} = 4 \times 2 \times 490.87 \text{ mm}^2 \times 434.78 \text{ N/mm}^2 / 1.11 = 1545.15 \text{ kN}$$

$$\beta \cdot v_{Ed} / v_{Rd,sy} = 0.72 \leq 1$$

OK

2.4 External round cut

$$l_s = 770 \text{ mm}$$

$$v_{Ed} = 1.10 \times 800.00 \text{ kN} / (5256 \text{ mm} \times 305 \text{ mm}) = 0.55 \text{ N/mm}^2$$

$$v_{Rd,ca} = \max [0.10 \times 1.81 \times (100 \times 0.0100 \times 35.00 \text{ N/mm}^2)^{1/3}; 0.50 \text{ N/mm}^2] = 0.59 \text{ N/mm}^2$$

$$v_{Ed} / v_{Rd,ca} = 0.93 \leq 1$$

OK

3. Selected strip elements

8 x JDA-2/25/295-440 (110/220/110)

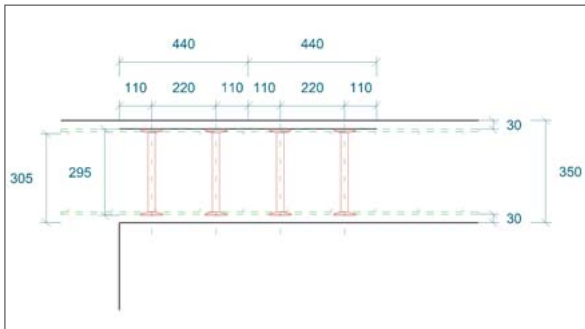

Section (from JORDAHL EXPERT® Software)

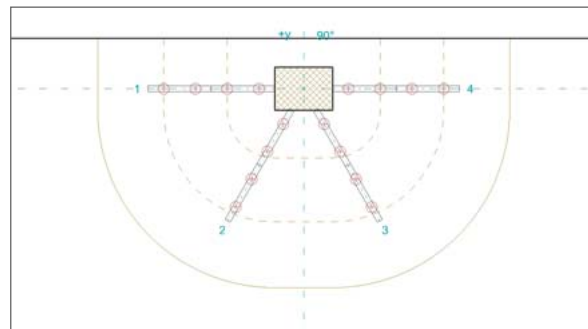

Plan view (from JORDAHL EXPERT® Software)

Dimensioning can be undertaken with the aid of the software JORDAHL® EXPERT Punching shear reinforcement JDA.

JORDAHL® EXPERT Punching Shear Reinforcement JDA

The basis for the program is the European Technical Approval ETA-13/0136 based on the Eurocode 2 (EN 1992-1-1).

Settings

Via Options / Settings users can define how the results of the calculations are determined:

- split standard elements
- piece-wise standard elements
- optimised separated elements
- continuous standard elements

Type of Support

- inner, edge and corner supports
- ends of walls and inner corners of walls

Advantages

- the most cost-effective solution is displayed first
- fast and clear entry of load specifications
- simple entry and structuring of projects
- printout of a verifiable structural calculation
- design load case earthquakes and fatigue
- 3D view of the support
- interactive insertion of edges
- influence of entered data is immediately visible and understandable
- for static calculation of site-placed concrete slabs, foundation slabs, precast planks/topping slabs and foundation blocks

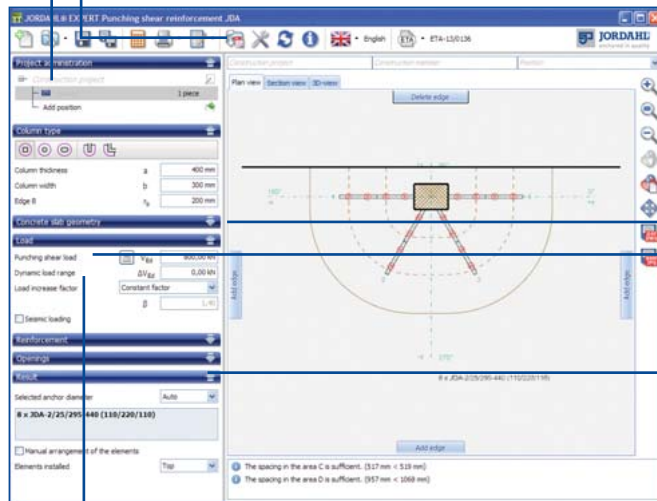

Load Increase

For the load increase factor β three selection possibilities exist:



- constant factor according to ETA-13/0136
- fully plastic shear stress distribution
- user-defined entry

Earthquake

The minimum degree of reinforcement for transverse forces is calculated in accordance with DIN 4149, and a detailed and easy to follow proof is provided.

Recesses

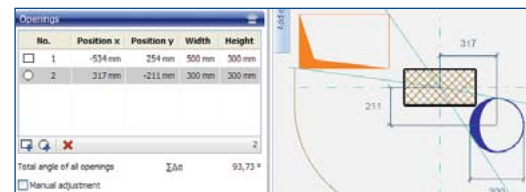

Reinforcement Ratio

Separate entry of the degree of reinforcement in the x and y directions for determination of the average degree of reinforcement ρ

- reinforcing bars
- reinforcement mesh with database of the most commonly used mesh types

- the effectiveness of the recess is checked automatically
- recesses can be easily inserted or moved at the click of a mouse
- the program automatically detects overlapping recesses
- manual entry of lengths to be subtracted for round cut
- direct correction of measured values within the drawing
- the locations of the opening are included on the printout of the recesses



Result

The presentation of the punching shear area in the plan view and the cross-sectional view provides an immediate overview of the arrangement of the JDA elements. Advantages:

- verifiable printout of result
- interim results, final results and proofs can be followed and understood very easily (punching shear, earthquake and bond proof)
- graphic result can be transmitted as *.DXF data file or *.DWG data file.

Printout of Result

Reproducible and comprehensive design printout with all of the information relevant to the test.

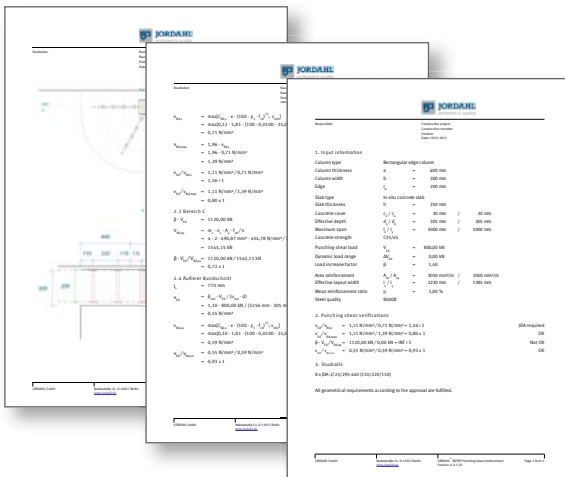

Manual Arrangement

JDA elements can be moved manually at the click of a mouse.

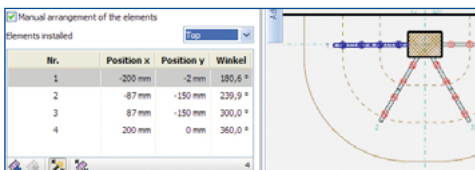

Views

Section

3D



Parts List / Invitation to Tender Form

All calculated items can be added to the parts list, which can also be called up as an ordering list. In addition, an invitation to tender form is automatically generated.

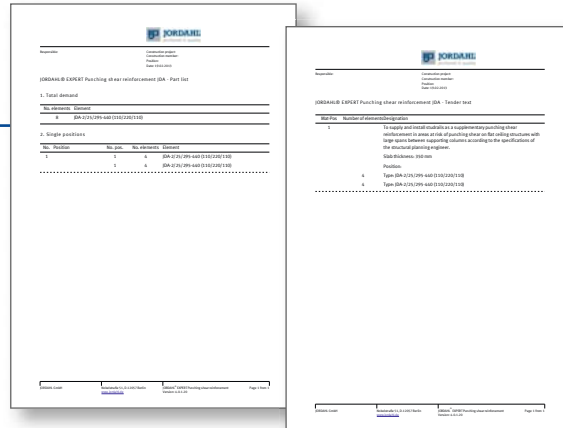

Bond Proof

The load-bearing capacity of the mounting and shear lattice girders can be calculated. The bond proof is carried out cost-effectively taking into account the double-headed anchors and lattice girders (expert report from RWTH Aachen). The provided output is a meaningful printout of the results.

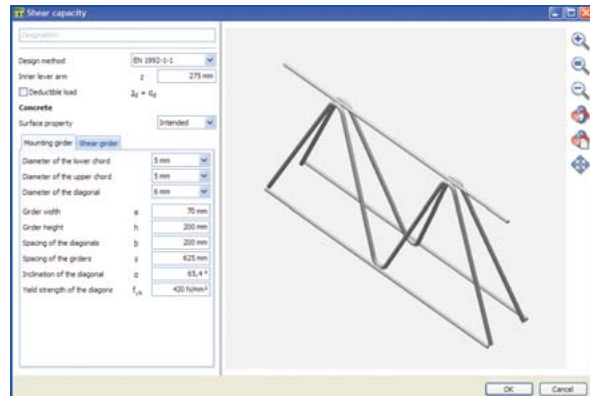

Determination of the Punching Shear Load

The punching shear load can be estimated with the aid of load collection surfaces.

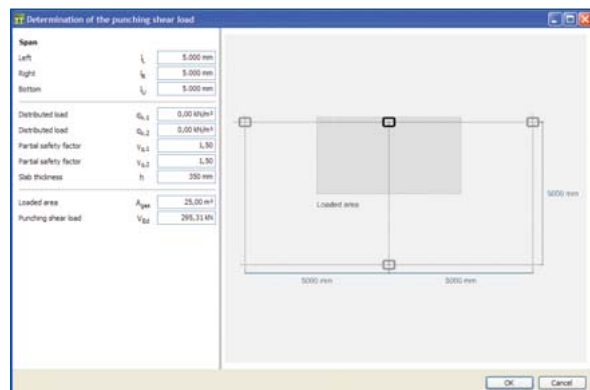

Installation

Layout in Practice

Positioning of the JDA Reinforcing Elements

For site-placed concrete ceilings we recommend installing the JDA elements from above. They can be positioned after completion of the entire reinforcement assembly.



Alignment of the Strip Overhang to the Edge of the Supporting Column

It is possible to check the position of the JDA elements and to correct them as required.



Safe Height Positioning

The double-headed anchors extend through the reinforcement layers.



Concreting the Slab

After alignment of the JDA elements the slab can be concreted.



Installation in Site-Placed Concrete

The JDA elements can be inserted in site-placed concrete optionally with the strips facing either up or down. In all cases the heads of the JDA anchors must extend through both layers of the bending reinforcement.

Pre-assembly with JDA-Q Installation Aids

1) Installation from above:

If the JDA reinforcing elements are arranged parallel to the upper reinforcement layer, the JDA-Q installation aid should be used and fastened with cotter pins.

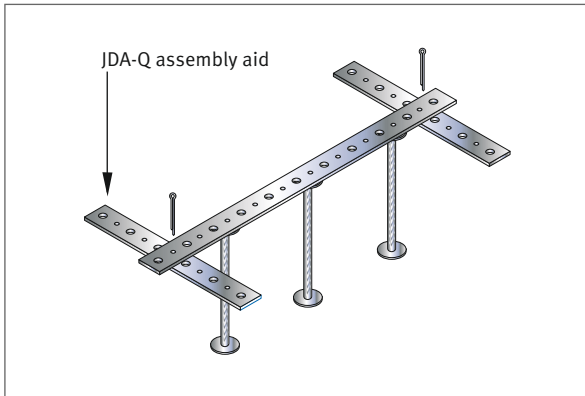

2) Installation from below:

JDA-Q installation aids can also be used here in order to improve the stability of the elements. The AH-DA spacers must be used in order to achieve the required concrete cover.

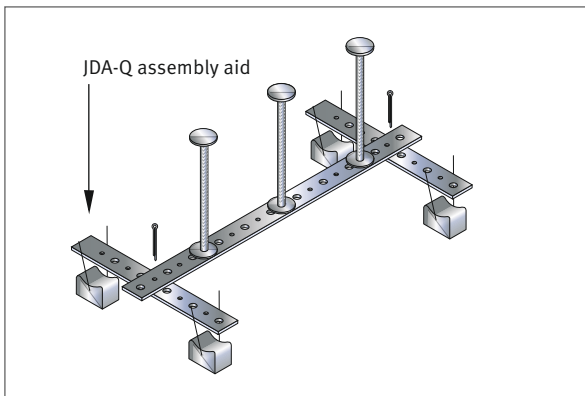

Note

Prior to installation, please compare the anchor diameters, anchor spacing and anchor height with the specifications in the formwork and reinforcement plans: the lower anchor heads must reach at least as far as the lower edge of the lowest reinforcement layer, the upper anchor heads at least as far as the upper reinforcement layer. All of the anchors used in the punch-

ing shear area of a supporting column must have the same diameter.



Layout

The reinforcing elements should be positioned in accordance with the planning requirements. If asymmetrical elements are used, the section marked in blue must be positioned facing the support.

The first strip protrusion is positioned flush against the edge of the support. If several standard elements are arranged in a row, the strips must butt up flush.

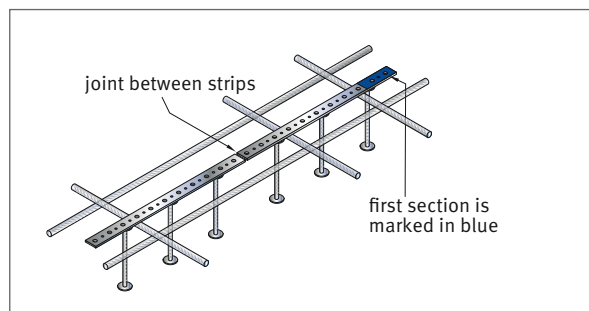
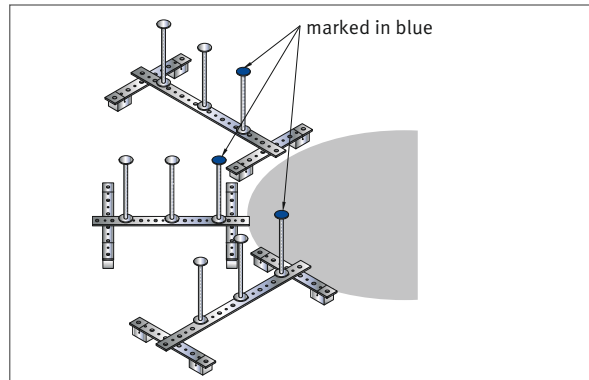

AH-DA Spacers

Suitable AH-DA spacers must be used for the installation of the JDA elements on the formwork. JORDAHL® offers spacers for concrete covers of 15, 20, 25, 30 and 35 mm.

Installation in Precast Plank / Topping Slabs

The JDA-FT-KL system has been specially developed for precast plank / topping slabs: the JDA elements are supplied unmounted, i.e. together as a kit comprising the anchors + connecting strips + spacers. This avoids any disruption of the automatic manufacturing process and prevents any fouling between the bending reinforcement and lattice girder with the JDA elements. On the construction site, the upper reinforcing layer can be installed without additional work and without assembly strips which get in the way.

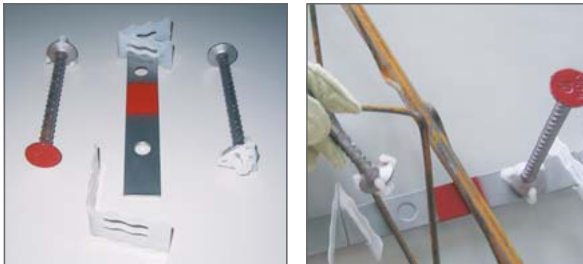

Advantages during Installation

- all parts of the element are supplied together as a kit
- colour coding is used to ensure clear assignment of components
- easy “click” installation even over longer distances
- anchor spacing always matches the quality requirements exactly
- no prohibited deviation in the anchor spacing
- spacers can be used universally
- the ceiling slab is ready for transport after concreting, no finishing is required
- perfect for keeping in storage
- technical training provided by JORDAHL employees, quality agreement

FBA Spacers

Suitable spacers have to be used for installation of the JDA elements in the prefabricating plant. JORDAHL offers fibre reinforced concrete spacers for concrete covers of 15, 20, 25 and 30 mm.



Installation

- 1) Assembly strips are positioned and secured according to the planning specifications on the spacers; these are required for subsequent mounting of the double-headed anchors.
- 2) Automatic arrangement of the grating supports and lower bending reinforcement.
- 3) The JDA double-headed anchors are clicked with the patented plastic connectors into the prepunched perforations in the assembly strip.



Connecting strip



Fastening of the connecting strips with spacers on the formwork



Double-headed anchors are snapped in place

AH-FT Spacers

Alternatively, plastic AH-FT spacers are available for installation of the JDA elements in the prefabricating plant. Each spacer can be used variably for four different thicknesses of concrete cover ($c = 15, 20, 25$ and 30 mm). These components offer maximum flexibility whilst minimizing storage space requirements.



Standard Elements Product Range

Punching Shear Reinforcement JDA, Dual Element

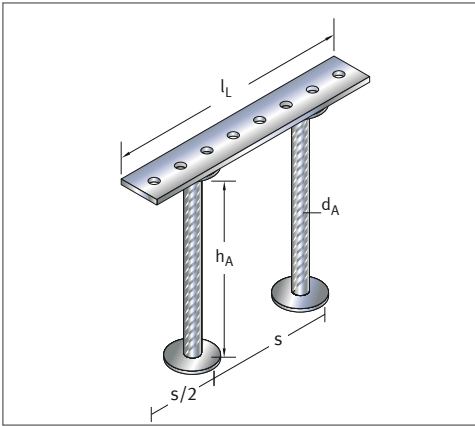

Punching Shear Reinforcement JDA, Triple Element

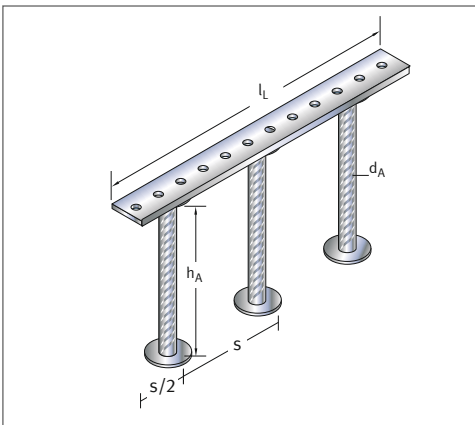

Is the size or design you require not included? No problem! Simply contact our JORDAHL experts, e.g. by e-mail at experten@jordahl.de. They provide friendly, fast and competent advice, and will also gladly develop an individual solution for your very specific application.

x on order: length according to customer request

– not possible

■ elements in stock, e.g. strip length 220 mm

■ product range JDA-FT-KL, only up to d_A 16 mm

other anchor lengths on request

Anchor length h_A [mm]	Anchor diameter d_A [mm]											
	10		12		14		16		20		25	
	2 Anch.	3 Anch.	2 Anch.	3 Anch.	2 Anch.	3 Anch.	2 Anch.	3 Anch.	2 Anch.	3 Anch.	2 Anch.	3 Anch.
	Connecting strip length l_L											
125	x	x	x	x	–	–	–	–	–	–	–	–
135	200	300	x	x	–	–	–	–	–	–	–	–
145	200	300	x	x	x	x	–	–	–	–	–	–
155	220 240	330 360	220 240	330	x	x	x	x	–	–	–	–
165	240	360	240	360	x	x	x	x	–	–	–	–
175	240	360	260	x	x	x	x	x	–	–	–	–
185	260 280	420	280	420	280	420	x	x	x	x	–	–
195	280	420	280 300	420 450	280 300	420 450	x	x	x	x	–	–
205	280 300	420 450	280 300	420 450	280 300	420 450	280	420	x	x	–	–
215	300	450	300	420 450	300	450	300	450	x	x	–	–
225	x	x	x	510	320 340	480 510	340	x	x	x	–	–
235	x	x	340	510	340	510	340	510	340	510	–	–
245	x	x	360	540	360	540	360	540	360	540	x	x
255	x	x	360	540	360	540	360	540	360	540	x	x
265	x	x	x	x	x	x	x	x	400	600	x	x
275	x	x	x	x	x	x	400	x	400	600	x	x
285	x	x	x	x	420	x	420	630	420	630	x	x
295	x	x	x	x	x	x	x	x	440	660	x	x
305	x	x	x	x	x	x	x	x	440	660	x	x
315	x	x	x	x	x	x	x	x	480	x	x	x
325	x	x	x	x	x	x	x	x	x	x	x	x
335	x	x	x	x	x	x	x	x	x	x	x	x
345	x	x	x	x	x	x	x	x	x	x	x	x
355	x	x	x	x	x	x	x	x	x	x	x	x
365	x	x	x	x	x	x	x	x	x	x	x	x
375	x	x	x	x	x	x	x	x	x	x	x	x
385	x	x	x	x	x	x	x	x	x	x	x	x
395	x	x	x	x	x	x	x	x	x	x	x	x
405	x	x	x	x	x	x	x	x	x	x	x	x
415	x	x	x	x	x	x	x	x	x	x	x	x
425	x	x	x	x	x	x	x	x	x	x	x	x
435	x	x	x	x	x	x	x	x	x	x	x	x
445	x	x	x	x	x	x	x	x	x	x	x	x
455	x	x	x	x	x	x	x	x	x	x	x	x
465	x	x	x	x	x	x	x	x	x	x	x	x
475	x	x	x	x	x	x	x	x	x	x	x	x
485	x	x	x	x	x	x	x	x	x	x	x	x
495	x	x	x	x	x	x	x	x	x	x	x	x
505	x	x	x	x	x	x	x	x	x	x	x	x
515	x	x	x	x	x	x	x	x	x	x	x	x
525	x	x	x	x	x	x	x	x	x	x	x	x
535	x	x	x	x	x	x	x	x	x	x	x	x
545	x	x	x	x	x	x	x	x	x	x	x	x
555	x	x	x	x	x	x	x	x	x	x	x	x
565	x	x	x	x	x	x	x	x	x	x	x	x
575	x	x	x	x	x	x	x	x	x	x	x	x
585	x	x	x	x	x	x	x	x	x	x	x	x
595	x	x	x	x	x	x	x	x	x	x	x	x
605	x	x	x	x	x	x	x	x	x	x	x	x
615	x	x	x	x	x	x	x	x	x	x	x	x
625	x	x	x	x	x	x	x	x	x	x	x	x
635	x	x	x	x	x	x	x	x	x	x	x	x
645	x	x	x	x	x	x	x	x	x	x	x	x
655	x	x	x	x	x	x	x	x	x	x	x	x
665	x	x	x	x	x	x	x	x	x	x	x	x
675	x	x	x	x	x	x	x	x	x	x	x	x
685	x	x	x	x	x	x	x	x	x	x	x	x
695	x	x	x	x	x	x	x	x	x	x	x	x

Service

Ordering Examples

Standard Element (with 2 or 3 Anchors)

Type	Number of anchors	Anchor d_A	Anchor length h_A	Connecting strip length l_L
JDA	2	14	255	360

Continuous Element

Type	Number of anchors	Anchor d_A	Anchor length h_A	Connecting strip length l_L
JDA	4	14	255	760

JDA-FT-KL (for Semi-Prefabricated Slab) (for precast planks/topping slabs)

Type	Version	Number of anchors	Anchor d_A	Anchor length h_A	Con.strip length l_L
JDA	FT-KL	2	14	255	380

Spacer AH-DA

Type	Concrete cover
AH-DA	20

Invitation to Tender Form for JORDAHL® Punching Shear Reinforcement

Supply JORDAHL® punching shear reinforcement JDA according to the European Technical Approval (ETA-13/0136), also for dynamic loading, as a supplement for reinforcement of areas at risk of punching shear of punctiform set flat slabs/of punctiform loaded slab-type foundations, deliver and install according to the instruction from the structural engineer.

Number of double-headed anchors =
 Anchor height h_A = mm · Anchor diameter d_A = mm
 Strip length l = mm
 Anchor separation / / / mm
 Unit: piece

All invitation to tender forms can be obtained at www.jordahl.de.

Installation Instructions/Videos

In order to obtain the best results when using JORDAHL products, various installation instructions and 3D videos are available at www.jordahl.de.

Invitation to Tender Forms

The pre-printed invitation to tender forms for all JORDAHL product ranges are available from www.jordahl.de with all of the relevant technical information on material, load-bearing capacity, sizes, as well as installation instructions.

The data can be exported, for example in GAEB format, and sent as an e-mail attachment or stored as a data file.

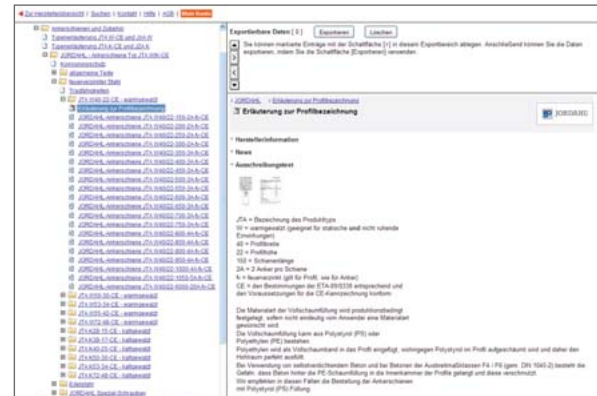

Catalogues

Are you interested in other JORDAHL products or would you like additional information on a specific product? Why not access our website? There are numerous brochures available to download from www.jordahl.de → [download](#).

Approval

The JORDAHL® punching shear reinforcement JDA has the European Technical Approval (ETA-13/0136). This is available to download from www.jordahl.de.



Fax enquiry

to 030 68283-498 or experten@jordahl.de

JDA Punching Shear Reinforcement

Sender: _____ Address: _____

Company: _____

Contact Person: _____

Tel/Fax: _____

Construction Project: _____

Space for a Diagram of the Distances between Supporting Edges and the Type of Support

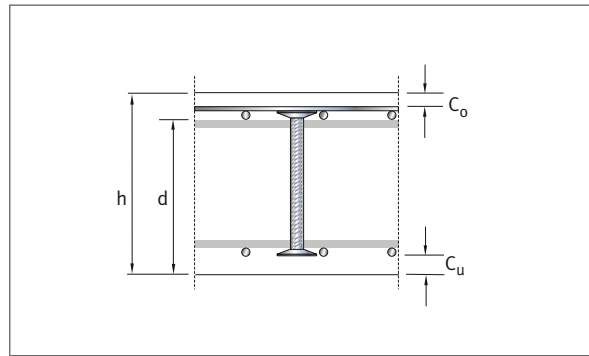
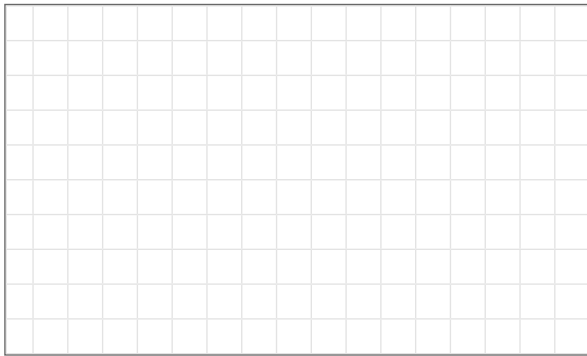

Request for a Design Proposal:

The following starting data are required in order to perform a verifiable calculation:

Concrete Strength C ____/____

Supporting Column dim. a/b = _____ cm

Slab Dimensions h = _____ cm d = _____ cm (where known)

c_o/c_u = _____ cm

Punching Shear Load: V_{Ed} = _____ kN

Site-placed Concrete Covering

Dynamic Load Range $V_{Ed, dyn}$ = _____ kN

Precast plank/topping slab

Reinforcement Ratio ρ = _____ %

Foundation Slab,
Bearing Load _____ kN/m²

or detailed reinforcement specifications: _____

Resulting moment load on the supporting column (where known): _____ kNm

JORDAHL GmbH

Nobelstr. 51
12057 Berlin

Tel + 49 30 68283-02
Fax + 49 30 68283-497

info@jordahl.de
www.jordahl.de

Notes

A large grid area for taking notes, consisting of a 30x30 grid of small squares.

Advice



Two of the JORDAHL Experts: Ralf Ratsch and Elisabeth Smith

The JORDAHL Experts

You are always well advised when you choose JORDAHL products. Whether from the point of view of static calculations, general technical advice/service or the development of customised solutions – competent and experienced JORDAHL product specialists offer you state-of-the-art, flexible and customised solutions for all your needs.

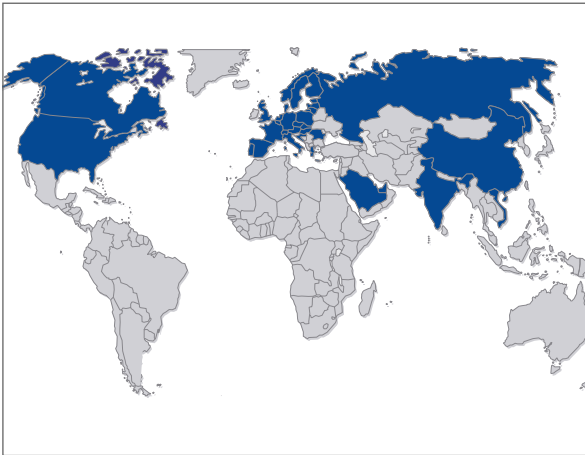

Throughout Europe and Around the World

JORDAHL products have proven themselves in use around the world because German quality standards are in demand everywhere. We can also guarantee perfect delivery of our products to you thanks to our reliable logistics partners and a perfectly functioning logistics chain (certified in accordance with DIN EN ISO 9001), because personalised, high-quality, customer-focused service is essential to us when it comes to delivery, too.

JORDAHL GmbH

Nobelstr. 51

12057 Berlin

Germany

Phone: + 49 30 68283-02

Fax: + 49 30 68283-497

www.jordahl.de

info@jordahl.de